

CATALOG NUMBER	"A" INTERFACE
S032-L43-05-T	FULL DETENT
S032-L45-05-T	SMOOTH BORE

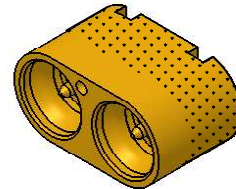

MATERIAL AND FINISH

HOUSING AND CENTER CONTACTS: IRON-NICKEL-COBALT SEALING ALLOY (KOVAR) PER ASTM F 15; GOLD PLATE 30 MICROINCHES MINIMUM OVER NICKEL PLATE 30 MICROINCHES MINIMUM.

DIELECTRICS: CORNING 7070 GLASS OR EQUIVALENT

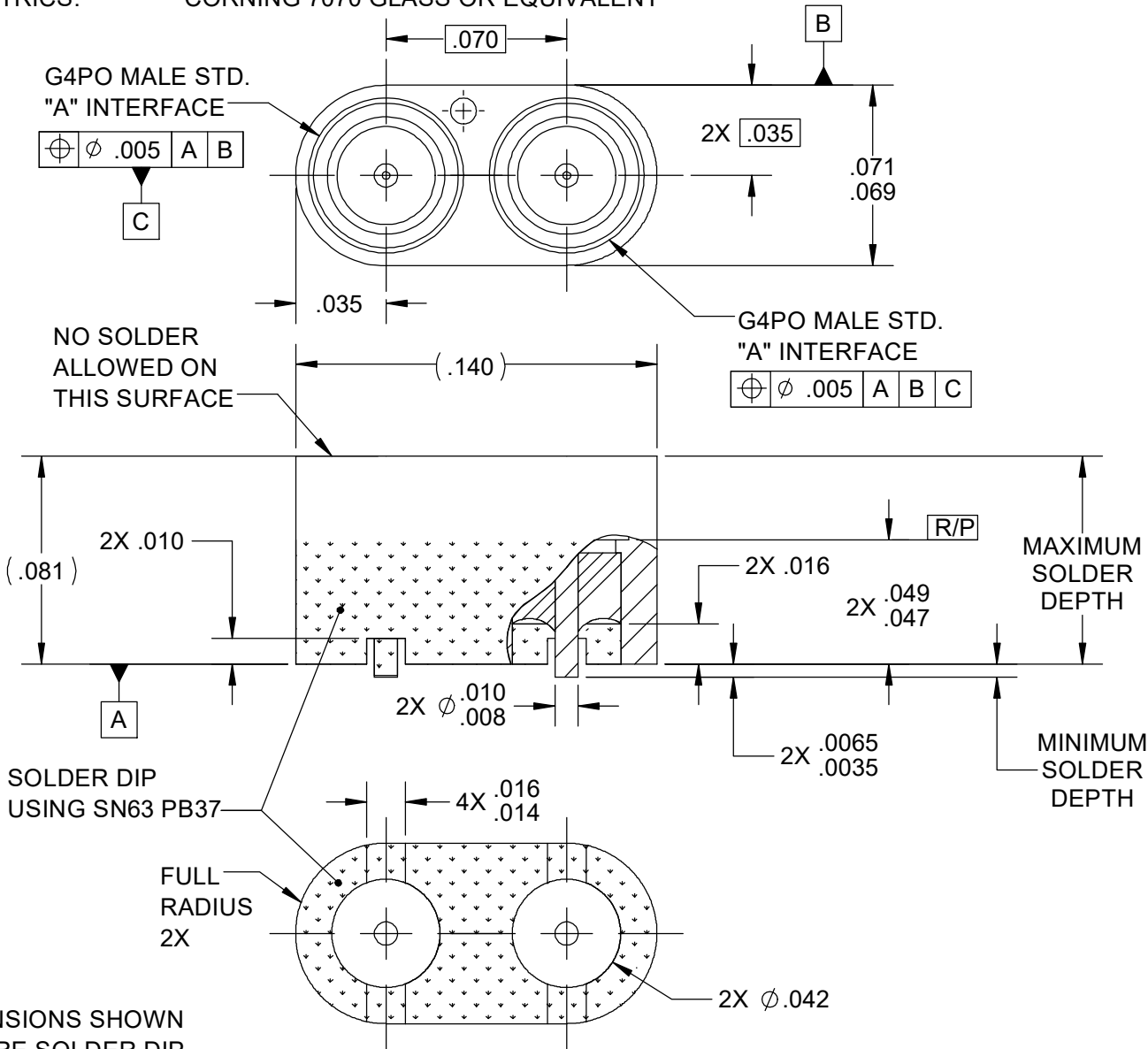

NOTES:
1. DIMENSIONS SHOWN BEFORE SOLDER DIP.

CORNING RESTRICTED - This drawing and any data contained herein is the proprietary and confidential information of Corning. Neither receipt nor possession of this drawing provides any right to duplicate, use, or disclose any information contained herein except with the express written consent of Corning.
EXPORT CONTROL - This document contains information within the purview of the Export Administration Regulations (EAR), 15 CFR 730-774, and may be export controlled.

APPROX. WEIGHT: 0.0633 grams	SIGNATURES	INIT	DATE:
TOLERANCE: .XX ±.010 .XXX ±.005 ANGULAR ±5°	DRAWN: TEF		2/15/16
	CHECKED: BLK		
	APPROVED: CRS		

G4PO MALE DUAL POSITION BLOCK (TAB DETENT)	CAGE CODE: 82316	SCALE: 16:1	CORNING	PLANT OF ORIGIN CORNING PHOENIX PLANT: (623)245-1050 CUSTOMER SERVICE: (800) 651-8869
	REVISION: 02			
SOURCE FILE: SK-5679	DWG. NO.: OL-S032-L4X-05-T	ASSY. PROC.: -		