

CATALOG NUMBER	A	BØ	C	"L" LENGTH(S)	MOUNTING HOLE
A007-L43-04-TAB	FD	.145	.120	SEE CHART	FIG. 1
A007-L44-04-TAB	LD	.145	.120	SEE CHART	FIG. 1
A007-L45-04-TAB	SB	.145	.120	SEE CHART	FIG. 1
A007-L43-03-TAB	FD	.164	.160	.030/.050/.075	FIG. 2
A007-L44-03-TAB	LD	.164	.160	.030/.050/.075	FIG. 2
A007-L45-03-TAB	SB	.164	.160	.030/.050/.075	FIG. 2

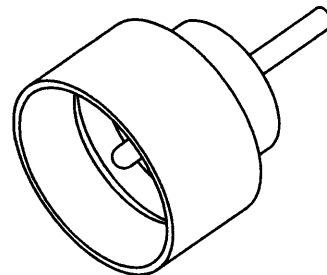

TAB EQUALS "L" x 10³ IN.

LENGTH CHART
.030
.050
.070
.090
.145

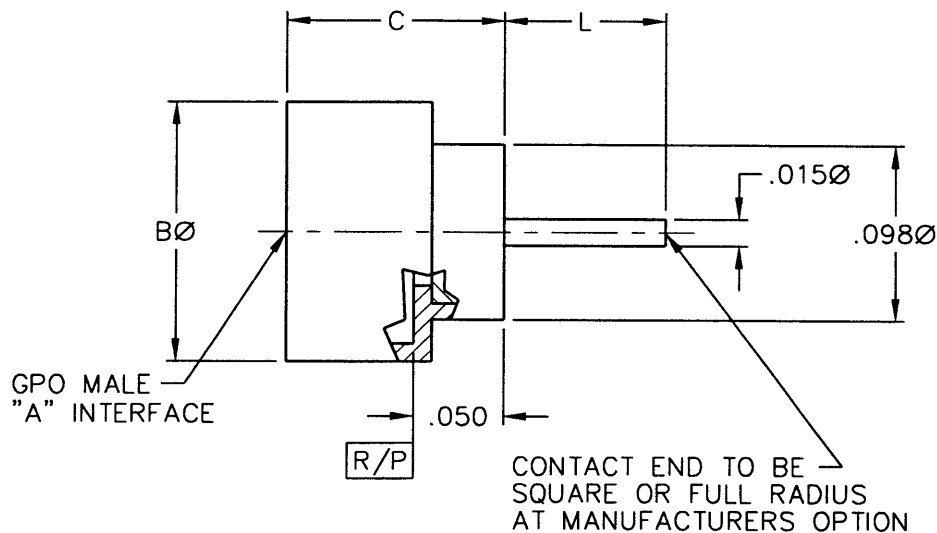

RECOMMENDED MOUNTING HOLES

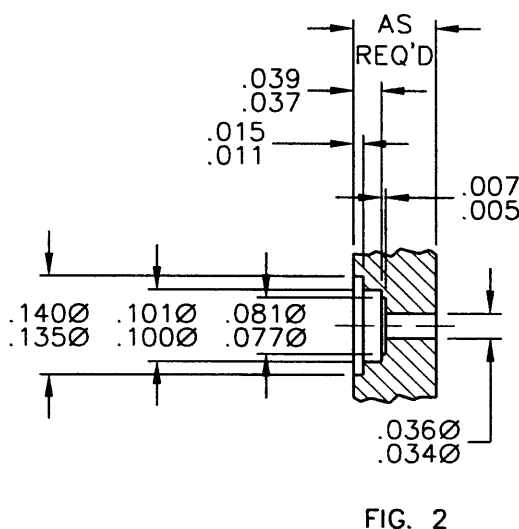
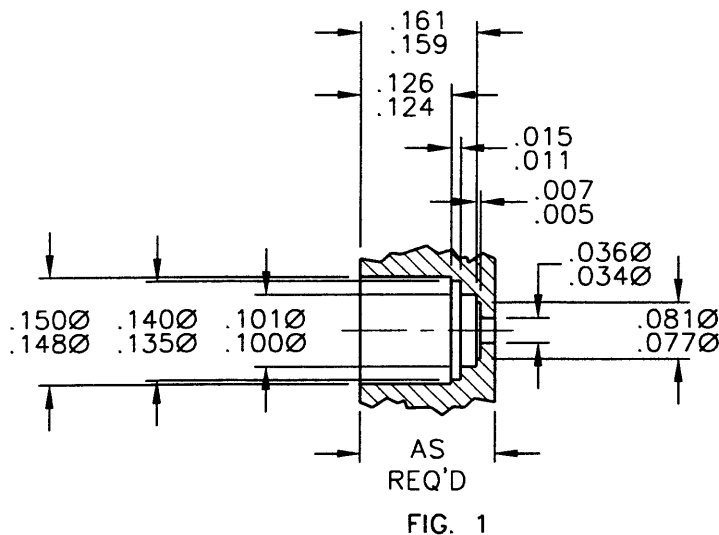

GPO MALE SOLDER-IN
HERMETIC SHROUD

Corning Gilbert Inc.

CODE IDENT NO.: 82316

SERIES: A007-L

MATERIAL AND FINISH: CODE 04

ASSEMBLY PROC.: -