

CATALOG NUMBER	"A" INTERFACE
A012-P93-09-T	FULL DETENT
A012-P94-09-T	LIMITED DETENT
A012-P95-09-T	SMOOTH BORE

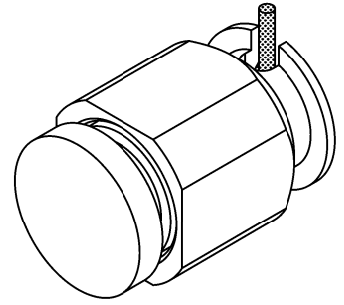

MATERIAL AND FINISH

CENTER CONTACT: BeCu; GOLD PLATE 75 MICROINCHES TYPICAL  
OVER NICKEL PLATE 100 MICROINCHES TYPICAL

HOUSING: BRASS; GOLD PLATE 75 MICROINCHES TYPICAL  
OVER NICKEL PLATE 100 MICROINCHES TYPICAL

DIELECTRIC: POLYAMIDE-IMIDE

SOLDER DIP SN 63 PB 37

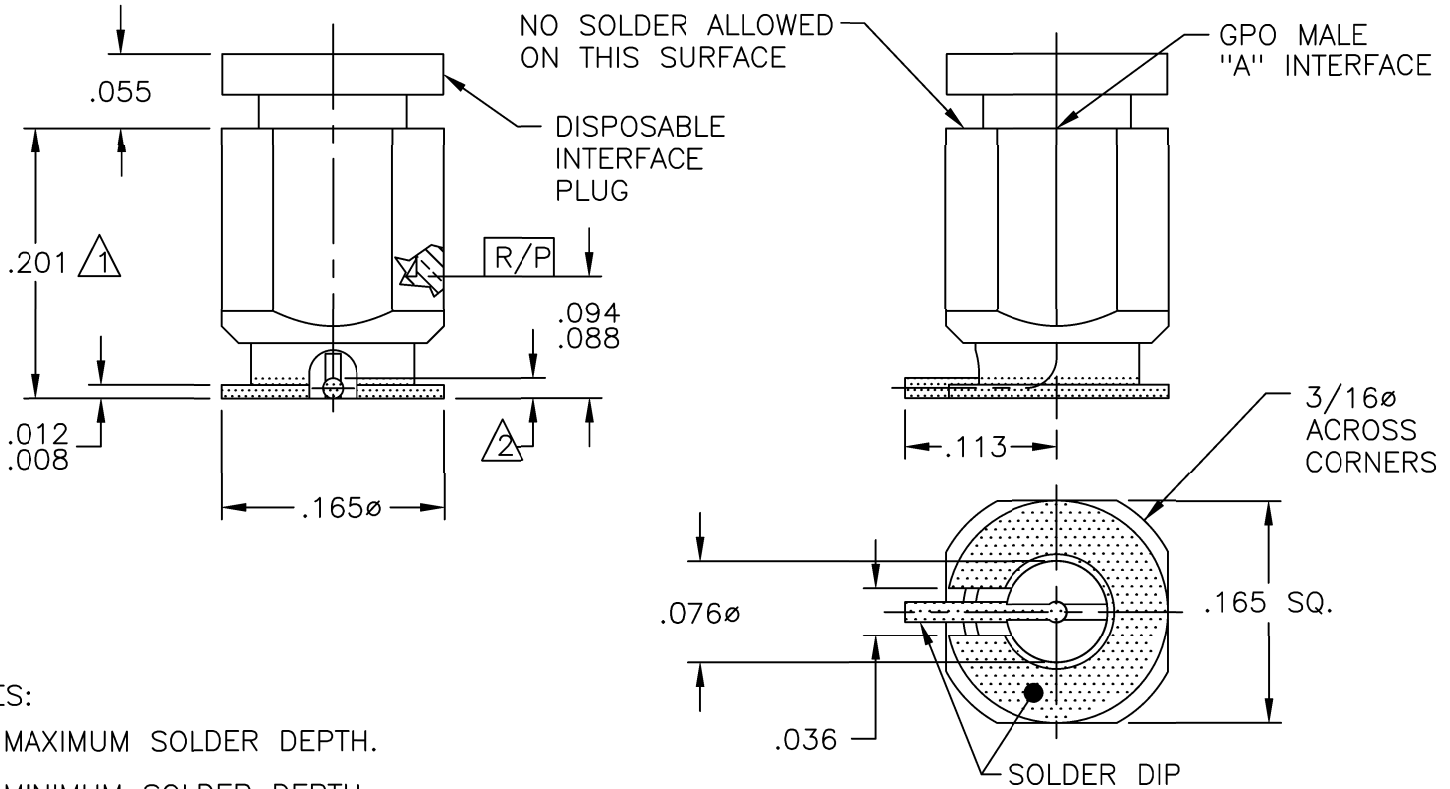

NOTES:

- $\triangle 1$  MAXIMUM SOLDER DEPTH.
- $\triangle 2$  MINIMUM SOLDER DEPTH.

RECOMMENDED MOUNTING FOOTPRINT

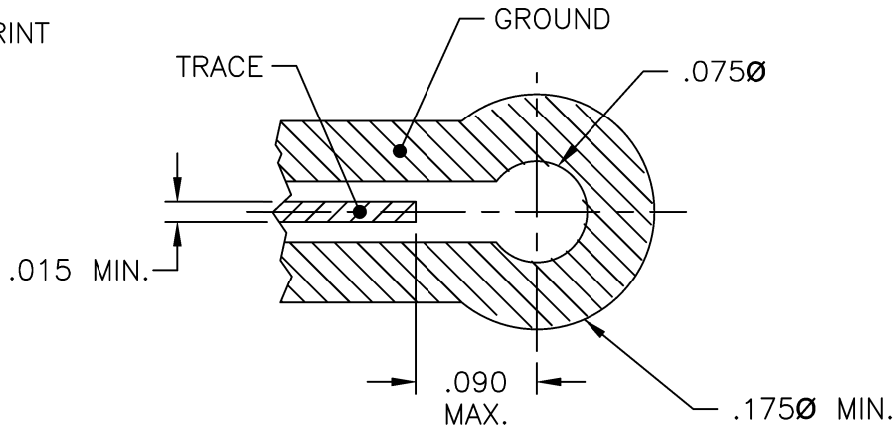

This drawing and any data contained herein is the property of Corning Gilbert Inc., and constitutes and contains proprietary and confidential information. Neither receipt nor possession of this drawing confers or transfers any right to duplicate, use or disclose any information contained herein except as expressly authorized by Corning Gilbert Inc.

GPO MALE (TAB DETENT)  
STRAIGHT TO COPLANAR  
LAUNCH SOLDER DIPPED

IDENT CODE:  
82316  
REVISION: A

**Corning Gilbert Inc.**

SOURCE FILE: SK-3426

DWG. NO.: OL-A012-P9X-09-T

ASSY. PROC.: -