

DATE REVISED: 8/21/10

CATALOG NUMBER	"A" INTERFACE
B012-P93-11-T	FULL DETENT
B012-P95-11-T	SMOOTH BORE

MATERIAL AND FINISH

CENTER CONTACT: BeCu; GOLD PLATE 75 MICROINCHES TYPICAL  
OVER NICKEL PLATE 100 MICROINCHES TYPICAL

HOUSING: BRASS; GOLD PLATE 75 MICROINCHES TYPICAL  
OVER NICKEL PLATE 100 MICROINCHES TYPICAL

DIELECTRIC STOP: POLYAMIDE-IMIDE

PLUG: VIRGIN PTFE

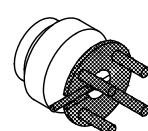
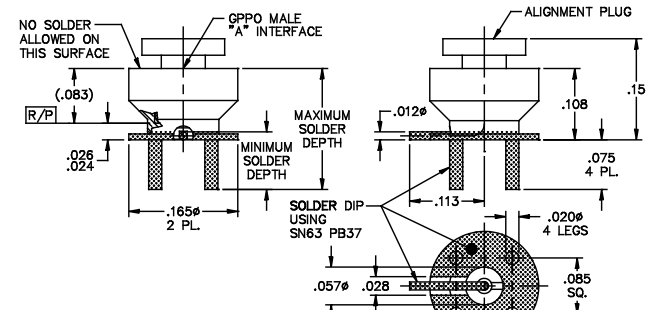
NOTES:  
1. DIMENSIONS SHOWN BEFORE SOLDER DIP.

RECOMMENDED MOUNTING FOOTPRINT

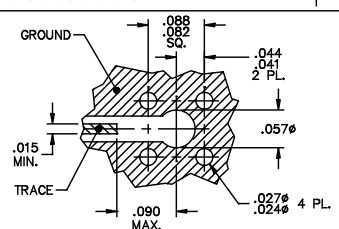

This drawing and any data contained herein is the property of Corning Gilbert Inc., and constitutes and contains proprietary and confidential information. Neither receipt nor possession of this drawing confers or transfers any right to duplicate, use or disclose any information contained herein except as expressly authorized by Corning Gilbert Inc.

GPPO MALE (TAB DETENT) COPLANAR SURFACE MOUNT SOLDER DIPPED	IDENT CODE: 82316	<b>Corning Gilbert Inc.</b>
	REVISION: B	

SOURCE FILE: SK-3616	DWG. NO.: OL-B012-P9X-11-T	ASSY. PROC.: —
----------------------	----------------------------	----------------