

CATALOG NUMBER	"A" INTERFACE
B012-L13-01	FULL DETENT
B012-L15-01	SMOOTH BORE

MATERIAL AND FINISH

CENTER CONTACT AND SHROUD:

BeCu; GOLD PLATE 50-100 MICRONS OVER NICKEL PLATE 50 MICRONS MIN.

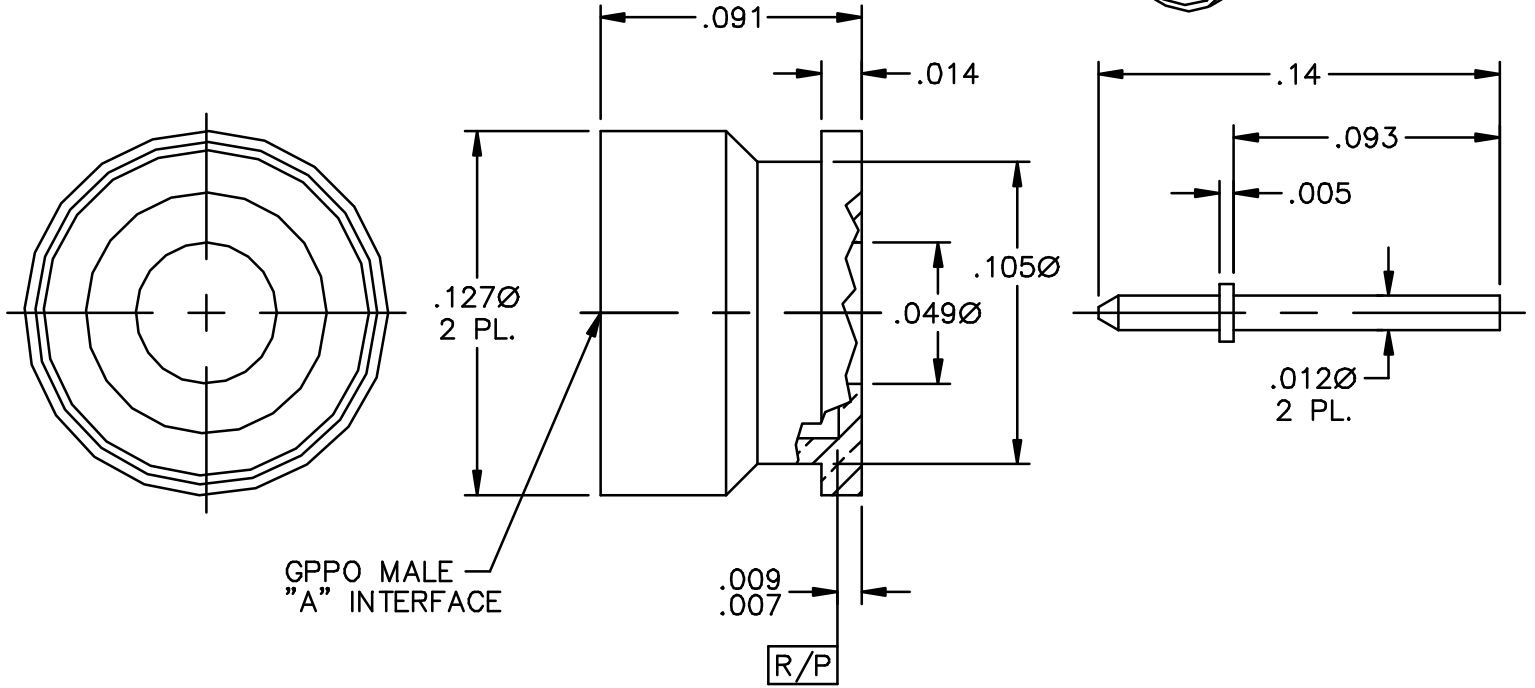
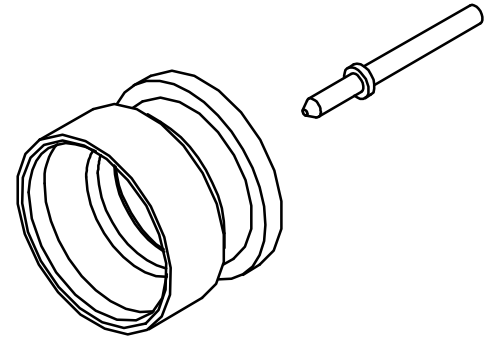

RECOMMENDED MOUNTING PATTERN

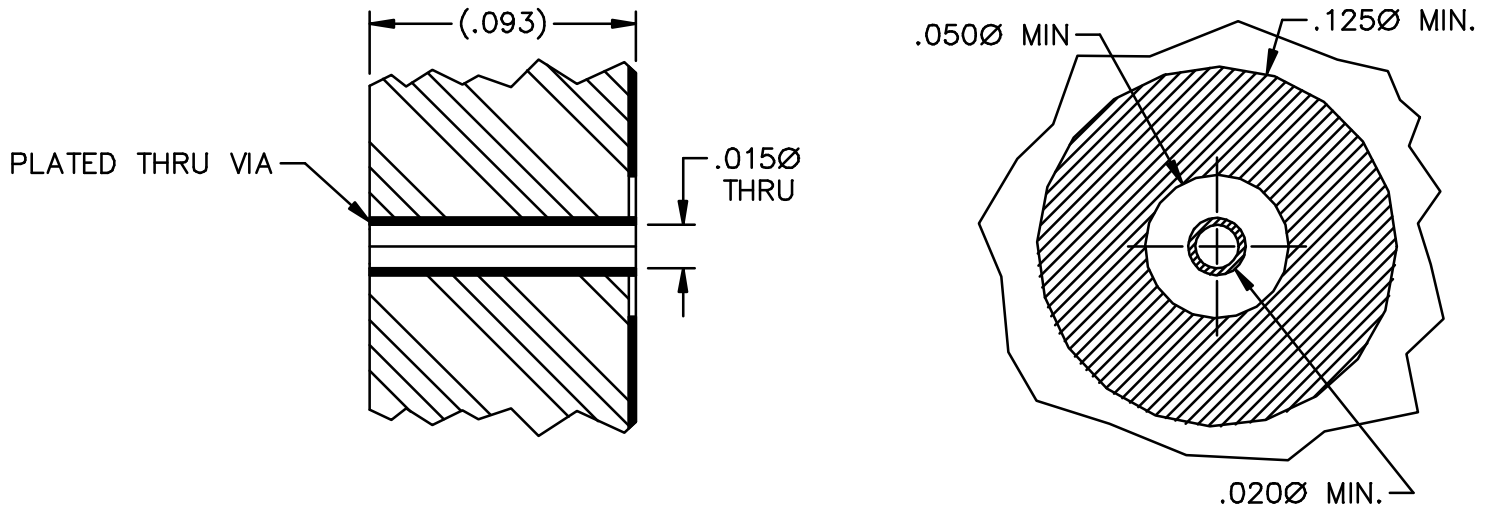

This drawing and any data contained herein is the property of Corning Gilbert Inc., and constitutes and contains proprietary and confidential information. Neither receipt nor possession of this drawing confers or transfers any right to duplicate, use or disclose any information contained herein except as expressly authorized by Corning Gilbert Inc.

GPPO MALE PCB SURFACE MOUNT WITH SEPARATE C/C (TAB DETENT)

IDENT CODE:  
82316

REVISION: B

**Corning Gilbert Inc.**

SOURCE FILE: MECR# 2319

DWG. NO.:

OL-B012-L1X-01

ASSY. PROC.:

-