

Male R/A PCB 4 Leg Thru Mount Cap C/C

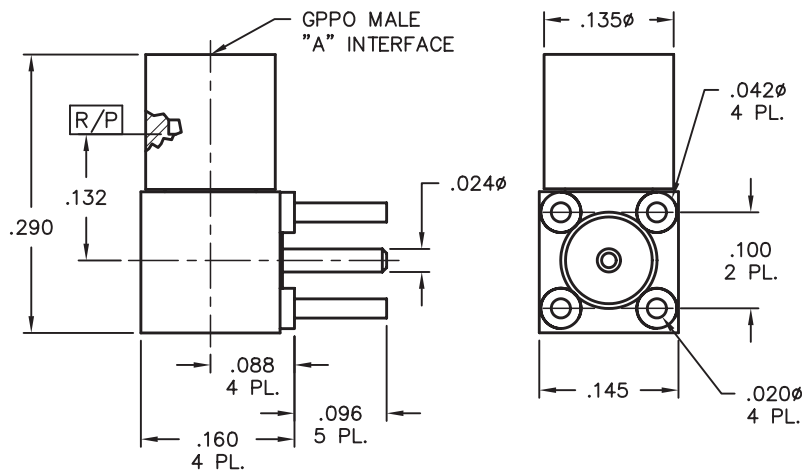

Catalog Number A

B009-P33-01 FD

B009-P35-01 SB

VSWR (TYP)

1.40:1 to 26.5 GHz



**Male R/A PCB Mount
0.135 Legs**

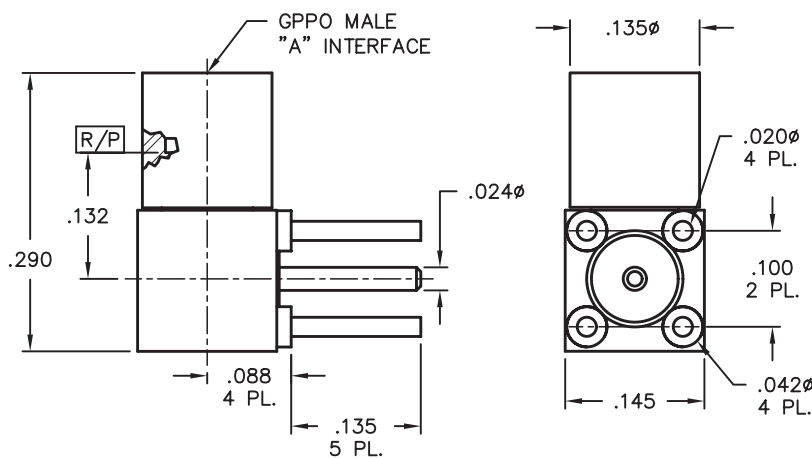

Catalog Number A

B009-P33-02 FD

B009-P35-02 SB

VSWR (TYP)

1.40:1 to 26.5 GHz



GPPO Flange Mounts

Male Flange Mount Shroud

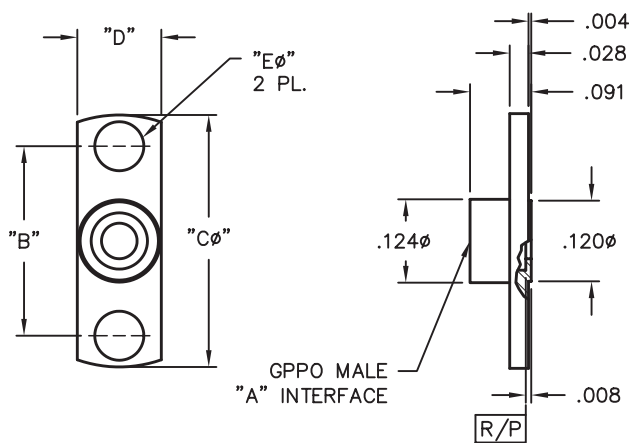

Catalog Number A B C ϕ D E ϕ

B001-A23-01 FD .282 .375 .125 .073

B001-A25-01 SB .282 .375 .125 .073

B001-A23-02 FD .481 .625 .150 .103

B001-A25-02 SB .481 .625 .150 .103

Tools Recommended

B090-A99-08 (for -02 series)

B090-A99-09 (for -01 series)

B090-A99-01

