

CATALOG NUMBER

B036-T45-01

MATERIAL AND FINISH

MOUNTING BLOCK
AND PINS:

IRON-NICKEL-COBALT SEALING ALLOY
(KOVAR) PER ASTM F 15; GOLD PLATE
MFS-104

DIELECTRICS:

CORNING 7070 GLASS

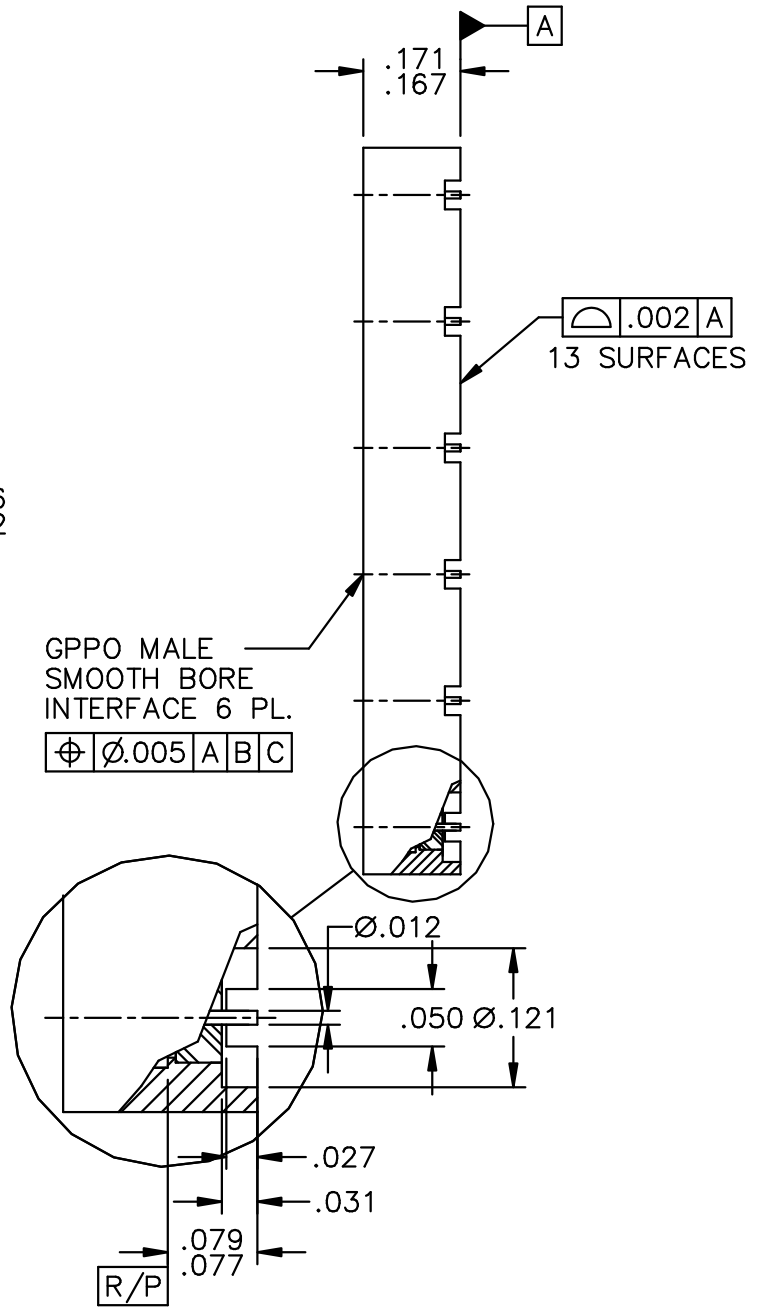
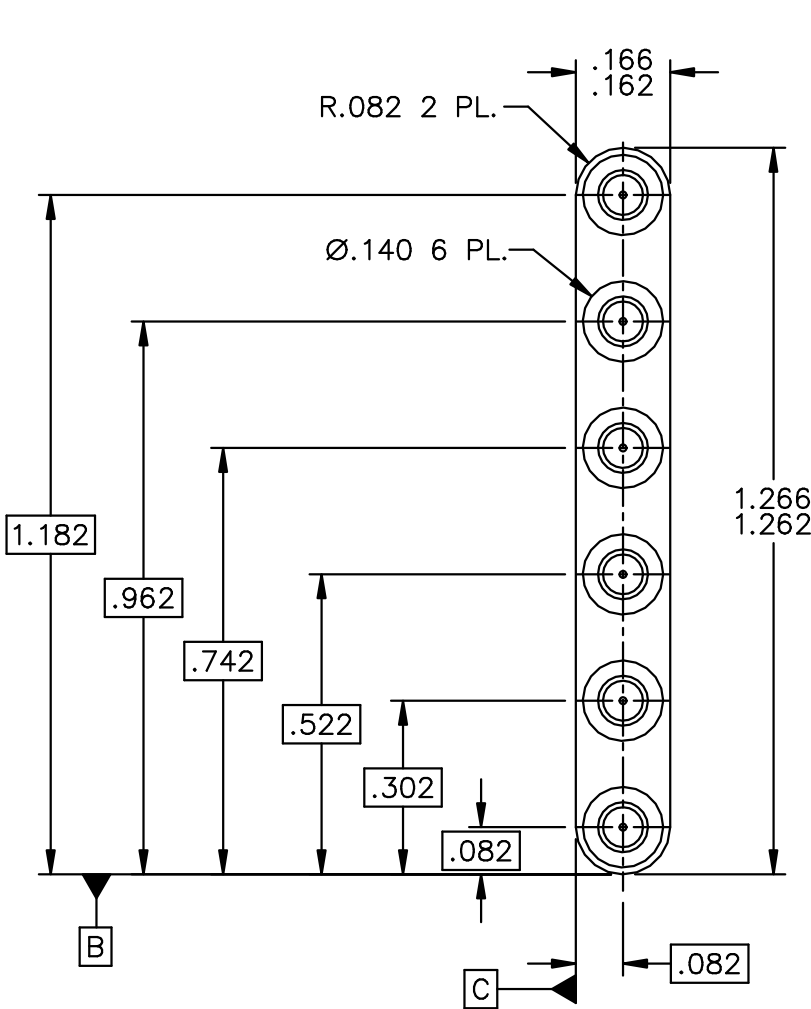
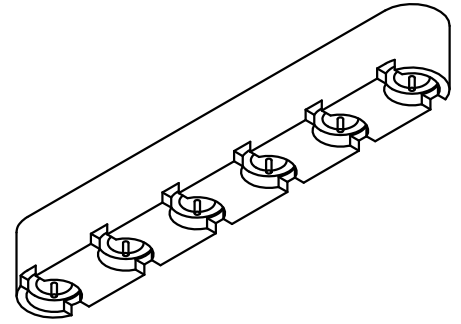

This drawing and any data contained herein is the property of Corning Gilbert Inc., and constitutes and contains proprietary and confidential information. Neither receipt nor possession of this drawing confers or transfers any right to duplicate, use or disclose any information contained herein except as expressly authorized by Corning Gilbert Inc.

GPPO MALE 6 POSITION
SMOOTH BORE SPECIAL
CATCHERS MITT MOUNTING BLOCK

IDENT CODE:
82316

REVISION: A

Corning Gilbert Inc.

SOURCE FILE: SK-3239

DWG. NO.: OL-B036-T45-01

ASSY. PROC.: -