

CATALOG NUMBER	"A" INTERFACE
B012-P93-10-T	FULL DETENT
B012-P95-10-T	SMOOTH BORE

MATERIAL AND FINISH

CENTER CONTACT: BeCu; GOLD PLATE 75 MICROINCHES TYPICAL
 OVER NICKEL PLATE 100 MICROINCHES TYPICAL
 HOUSING: BRASS; GOLD PLATE 75 MICROINCHES TYPICAL
 OVER NICKEL PLATE 100 MICROINCHES TYPICAL
 DIELECTRIC: POLYAMIDE-IMIDE
 PLUG: VIRGIN PTFE

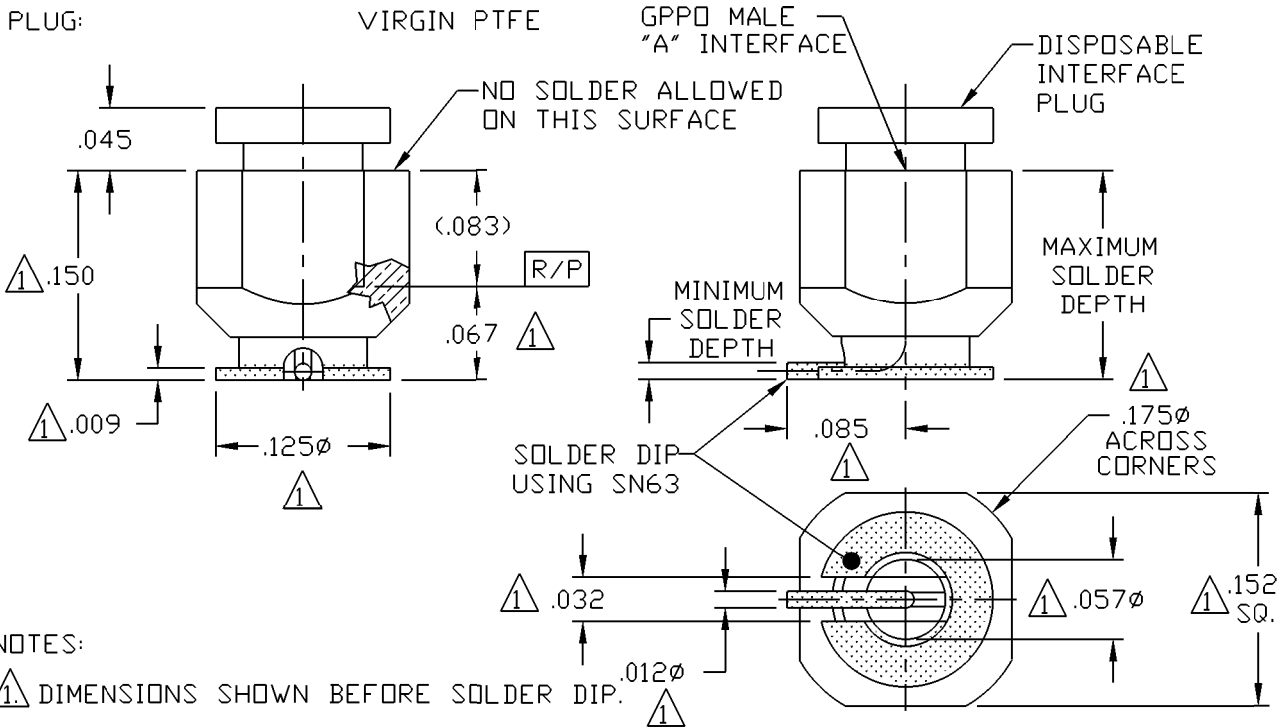
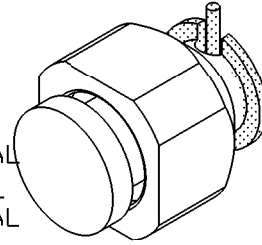

RECOMMENDED FOOTPRINT

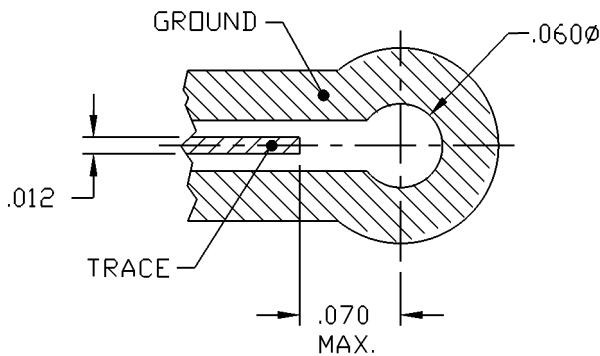

This drawing and any data contained herein is the property of Corning Gilbert Inc., and constitutes and contains proprietary and confidential information. Neither receipt nor possession of this drawing confers or transfers any right to duplicate, use or disclose any information contained herein except as expressly authorized by Corning Gilbert Inc.

GPPO MALE (TAB DETENT)
 SURFACE MOUNT
 (SOLDER DIPPED)

IDENT CODE:
 82316
 REVISION: A

Corning Gilbert Inc.

SOURCE FILE: MECR# 3144

DWG. NO.: 0L-B012-P9X-10-T

ASSY. PROC.: -