

CATALOG NUMBER	"A" INTERFACE
B013-L93-01	FULL DETENT
B013-L95-01	SMOOTH BORE

MATERIAL AND FINISH

CENTER CONTACT: BeCu; GOLD PLATE 75 MICROINCHES TYPICAL
 OVER NICKEL PLATE 100 MICROINCHES TYPICAL
 HOUSING: BRASS; GOLD PLATE 75 MICROINCHES TYPICAL
 OVER NICKEL PLATE 100 MICROINCHES TYPICAL
 DIELECTRIC: POLYETHERIMIDE

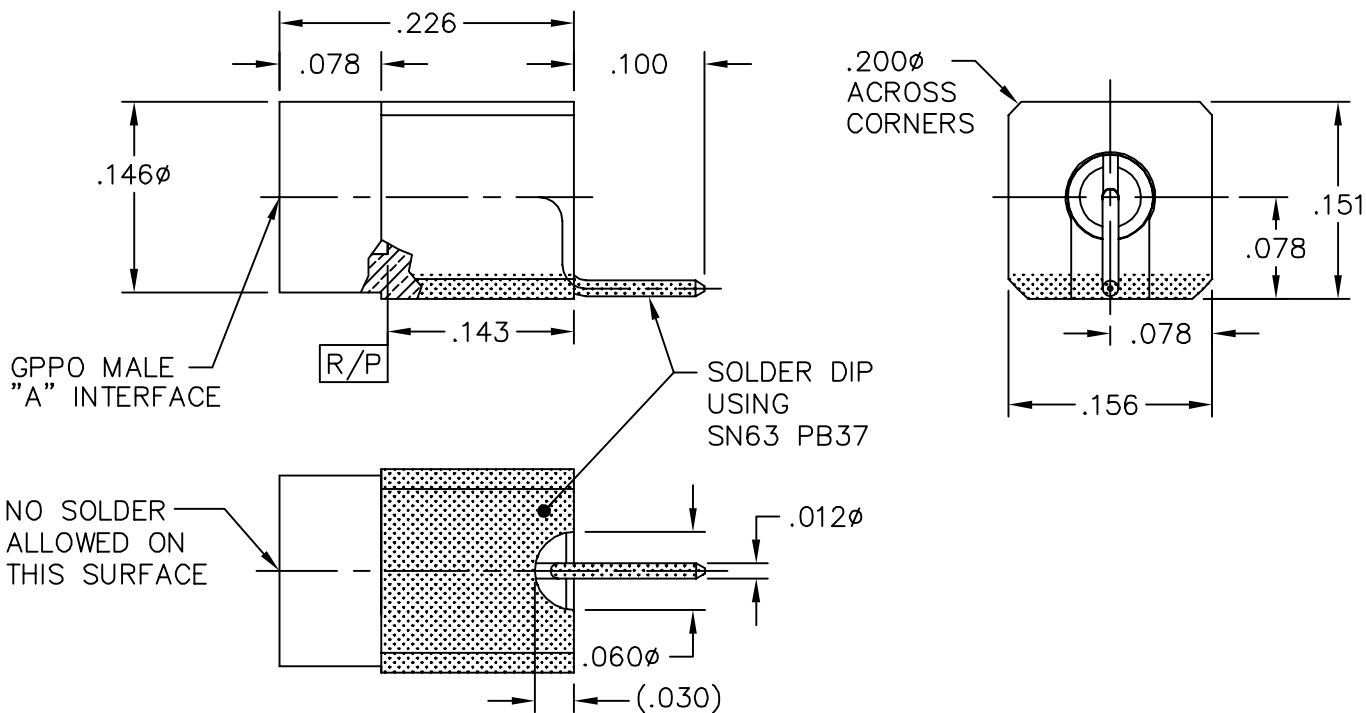
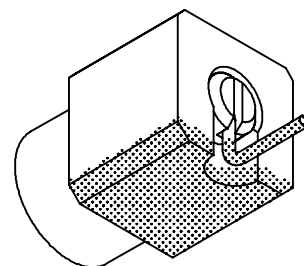

MOUNTING DETAIL

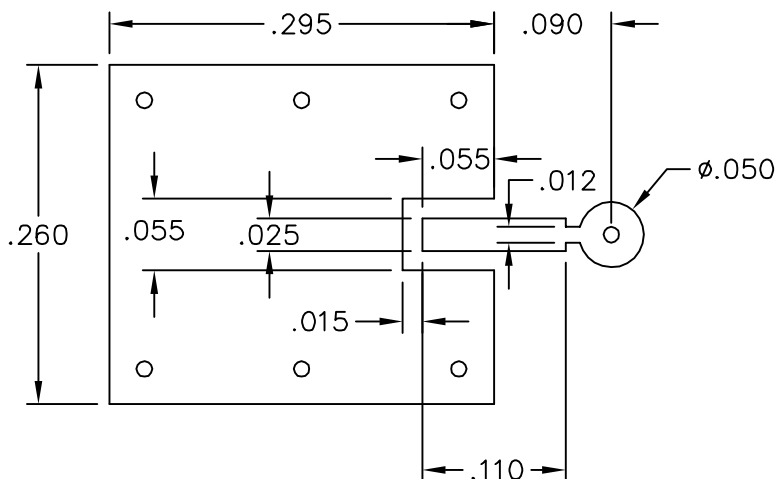

INSTALLED VIEW

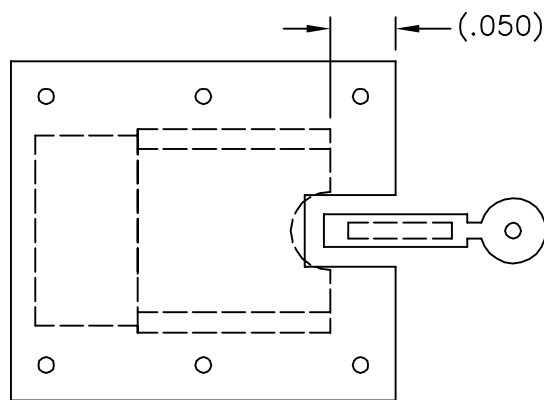

This drawing and any data contained herein is the property of Corning Gilbert Inc., and constitutes and contains proprietary and confidential information. Neither receipt nor possession of this drawing confers or transfers any right to duplicate, use or disclose any information contained herein except as expressly authorized by Corning Gilbert Inc.

GPPO MALE (TAB DETENT)
 R/A SURFACE MOUNT
 SOLDER DIPPED

IDENT CODE:
 82316

REVISION: H1

Corning Gilbert Inc.

SOURCE FILE: SK-2056

DWG. NO.: OL-B013-L9X-01

ASSY. PROC.: -