

CATALOG NUMBER	"A" INTERFACE
B012-T73-01-T	FULL DETENT
B012-T75-01-T	SMOOTH BORE

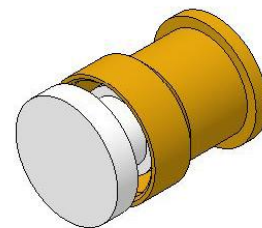

MATERIAL AND FINISH

CENTER CONTACT AND SHROUD: BeCu; GOLD PLATE 75 MICRONS TYPICAL OVER NICKEL PLATE 100 MICRONS TYPICAL

DIELECTRIC: POLYAMIDE-IMIDE

ALIGNMENT PLUG: VIRGIN PTFE

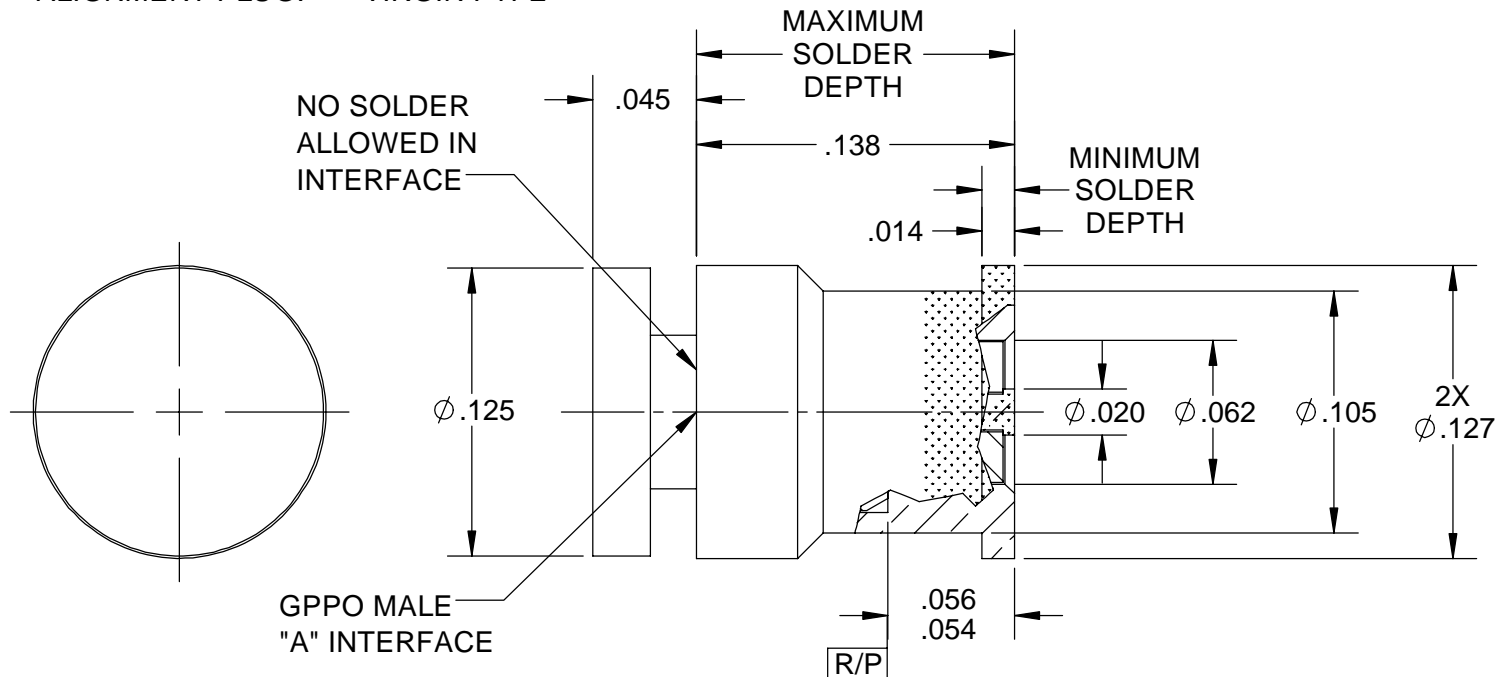

NOTES:

- ALL DIMENSIONS APPLY PRE-SOLDER DIP UNLESS OTHERWISE SPECIFIED.

RECOMMENDED MOUNTING PATTERN

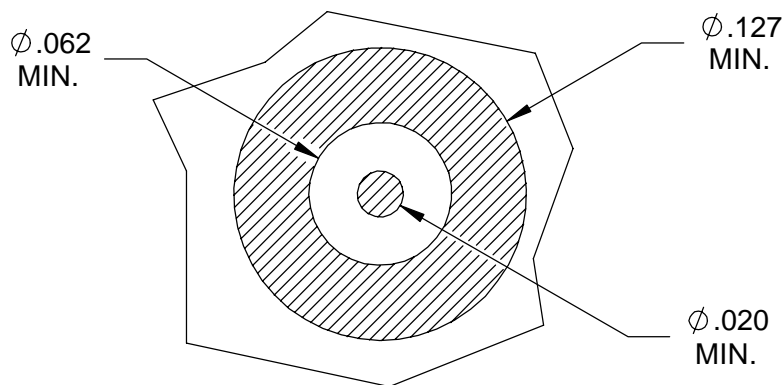

CORNING RESTRICTED - This drawing and any data contained herein is the proprietary and confidential information of Corning. Neither receipt nor possession of this drawing provides any right to duplicate, use, or disclose any information contained herein except with the express written consent of Corning.
EXPORT CONTROL - This document contains information within the purview of the Export Administration Regulations (EAR), 15 CFR 730-774, and may be export controlled.

APPROX. WEIGHT: 0.1270 grams	SIGNATURES	INIT	DATE:
TOLERANCE: .XX ±.010 .XXX ±.005 ANGULAR ±5°	DRAWN: DMG		11/20/15
	CHECKED: BLK		
	APPROVED: TEF		

GPPO MALE PCB SURFACE MOUNT SOLDER DIPPED (TAB DETENT)	CAGE CODE: 82316	SCALE: 12:1	CORNING	PLANT OF ORIGIN CORNING PHOENIX PLANT: (623)245-1050 CUSTOMER SERVICE: (800) 651-8869
	REVISION: 01			

SOURCE FILE: SK-4969	DWG. NO.: OL-B012-T7X-01-T	ASSY. PROC.: -
-----------------------------	-----------------------------------	-----------------------