

CAD DRAWING - NO MANUAL REVISIONS

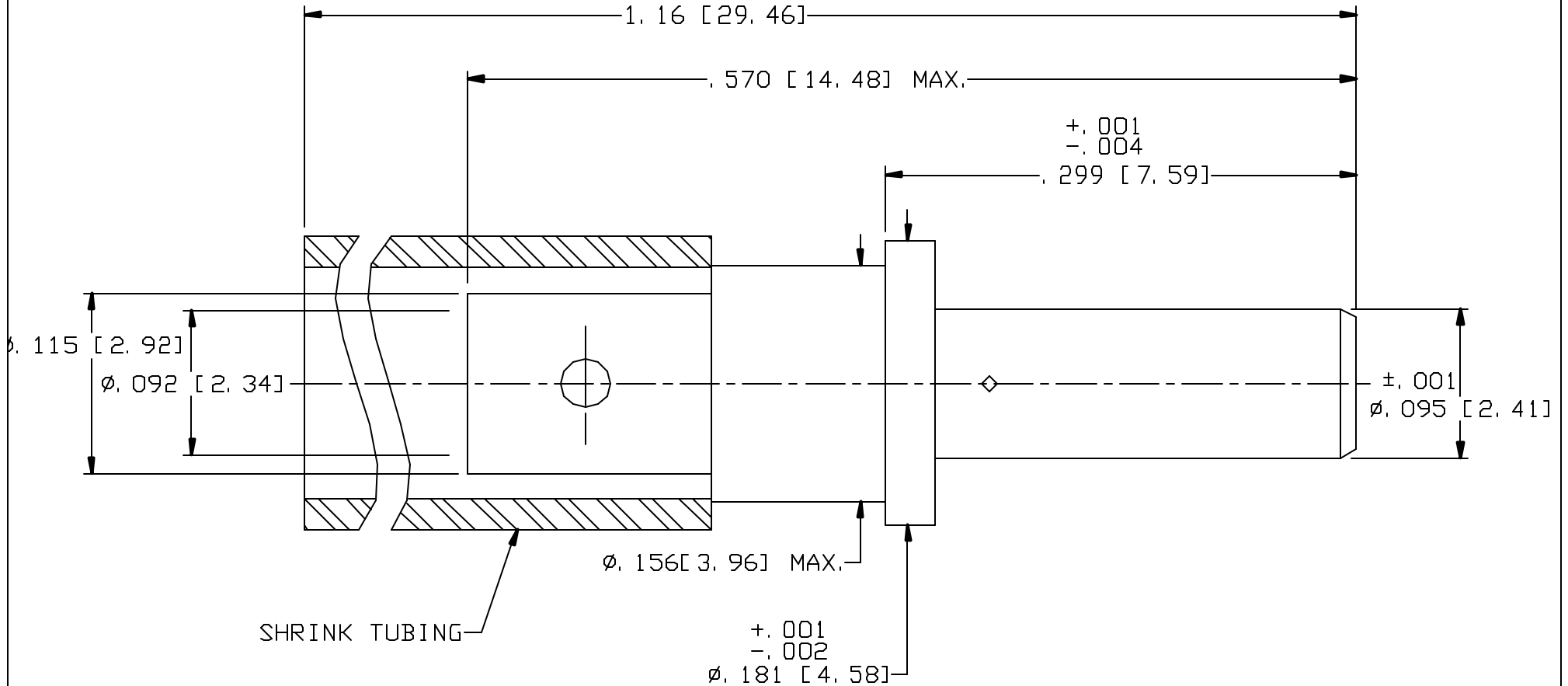

NOTES:

1. DESIGN AND INTERFACE PER I. D. D. -56B.
2. PROCESS ALL ECNs PER DS-12.
3. ACCOMMODATES TIMES T-FLEX 405 CABLE.
4. USED IN MIL-C-38999 SERIES I-IV CONNECTORS.

				<p>PALCO CONNECTOR</p> <p>22 GREAT HILL RD., NAUGATUCK, CT 06770</p> <p>UNLESS OTHERWISE SPECIFIED, PALCO WORKMANSHIP STANDARDS APPLY</p> <p>TOLERANCES ON DECIMALS: XX \pm.01 .XXX \pm.005 ANGLES \pm1/32</p> <p>DIMENSIONS IN INCHES OR (METRIC) DO NOT SCALE PRINTS</p> <p>MAT.: EPR 8621; LOCKHEED SANDERS</p>	DRAWN JEM	CHECKED HN	ENGINEER JEM	APPROVED HN	FSCM 58167
D	PER ECN 8101	07/21/05	JEM			DESCRIPTION SIZE 12 PKZ PLUG, DIRECT SOLDER			
C	PER ECN 4441	03/24/98	HN			DATE 06/10/97	DRAWING NO. 56-0021-0861	PLATING OPT. A	
B	PER ECN 4053	09/05/97	HN						
A	REL. ECN 3933	06/10/97	HN						
REV.	DESCRIPTION	DATE	APPR.						