

PART NUMBER	ITEM ① BODY	ITEM ② CONTACT	ITEM ③ INSULATOR	ITEM ④ CRIMP SLEEVE
133-3304-001	BRASS GOLD PL .00001 MIN OVER NICKEL PL .00005 MIN OVER COPPER PL .00005 MIN	BERYLLIUM COPPER GOLD PL .00003 MIN OVER NICKEL PL .00005 MIN OVER COPPER PL .00005 MIN	TEFLON	COPPER GOLD PL .00001 MIN OVER NICKEL PL .00005 MIN OVER COPPER PL .00005 MIN
131-3304-006	BRASS NICKEL PL .0001 MIN OVER COPPER PL .00005 MIN	BERYLLIUM COPPER GOLD PL .00003 MIN OVER NICKEL PL .00005 MIN OVER COPPER PL .00005 MIN	TEFLON	COPPER NICKEL PL .0001 MIN OVER COPPER PL .00005 MIN

DRAWING NO. C - 133-3304-001/010			
0 REVISIONS			
ENGINEERING RELEASE			
1	11-16-95	R H R R	ECN 43786
RF LEAKAGE -55 DB WAS -7D 5.6 LBS MAX ENGAGE WAS 3.4 LBS. 1.0 / 8.0 LBS DISENGAGE WAS 2.25 / 4.5 CONTACT RETENTION 2.3 LBS WAS 4.0			
* REVISION NUMBER FOLLOWED BY AN ALPHA * * CHARACTER INDICATED DRAWING CLASS * * CATION OR PART NUMBER ADDITION ONLY *			
1a	12-19-00	R H R R	ECN 47531

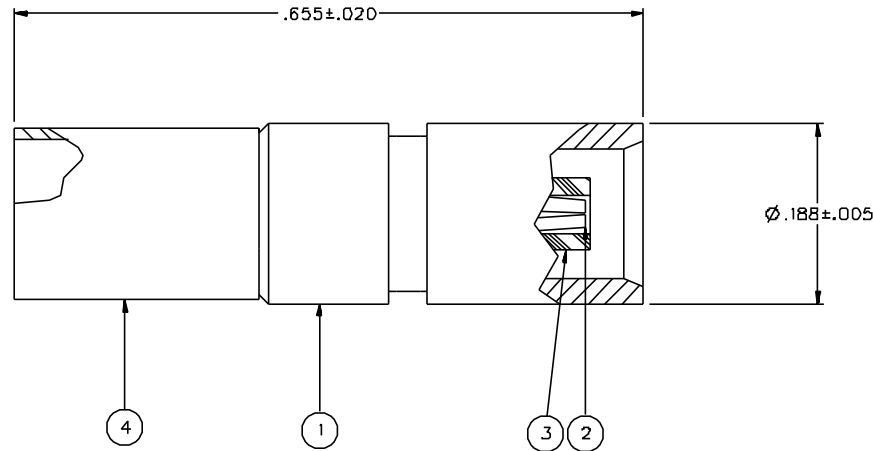

NOTES:

1. SPECIFICATIONS:

IMPEDANCE: 50 OHMS
 FREQUENCY RANGE: 0-6 GHz
 VSWR: 1.13-.04F MAX (F IN GHz)
 WORKING VOLTAGE: 335 VRMS MAX AT SEA LEVEL
 DIELECTRIC WITHSTANDING VOLTAGE: 1000 VRMS MIN AT SEA LEVEL
 INSULATION RESISTANCE: 10000 MEGOHM MIN
 CONTACT RESISTANCE:
 CENTER CONTACT - INITIAL 5 MILLIOHM MAX, AFTER ENVIRONMENTAL 8 MILLIOHM MAX
 OUTER CONDUCTOR - GOLD PLATED INITIAL 1 MILLIOHM MAX, AFTER ENVIRONMENTAL 1.5 MILLIOHM MAX
 NICKEL PLATED INITIAL 2.5 MILLIOHM MAX, AFTER ENVIRONMENTAL 3.5 MILLIOHM MAX
 BODY TO CABLE - GOLD PLATED INITIAL 1 MILLIOHM MAX, AFTER ENVIRONMENTAL NOT APPLICABLE
 NICKEL PLATED INITIAL 2.5 MILLIOHMS MAX, AFTER ENVIRONMENTAL NOT APPLICABLE
 CORONA LEVEL: 250 VOLTS MINIMUM AT 70,000 FEET
 INSERTION LOSS: .1DB MAX AT 1 GHz
 RF LEAKAGE: -55 DB AT 2.5 GHz
 RF HIGH POTENTIAL WITHSTANDING VOLTAGE: 70D VRMS AT 4 AND 7 MHZ

MECHANICAL:

ENGAGE/DISENGAGE FORCE: 5.6 LBS MAX ENGAGEMENT
 1.0 LB MIN DISENGAGEMENT
 8.0 LBS MAX DISENGAGEMENT

CONTACT RETENTION FORCE: 2.3 LBS MIN
 CONTACT RETENTION TORQUE: NOT APPLICABLE
 COUPLING MECHANISM RETENTION: NOT APPLICABLE
 CABLE ACCEPTABILITY: RG 188/U DOUBLE SHIELD, RG 316/U DOUBLE SHIELD,
 RG 179/U DOUBLE SHIELD, RG 187/U DOUBLE SHIELD

CABLE HEX CRIMP SIZE: .151
 CABLE RETENTION: 25 LBS MIN AXIAL FORCE
 DURABILITY: 500 CYCLES MIN

ENVIRONMENTAL:

{MEETS OR EXCEEDS THE APPLICABLE PARAGRAPH OF MIL-C-39012}
 THERMAL SHOCK: MIL-STD-202, METHOD 107, CONDITION F
 OPERATING TEMPERATURE: -65 DEG C TO 165 DEG C
 CORROSION: MIL-STD-202, METHOD 101, CONDITION B
 SHOCK: MIL-STD-202, METHOD 213, CONDITION B
 VIBRATION: MIL-STD-202, METHOD 204, CONDITION B
 MOISTURE RESISTANCE: MIL-STD-202, METHOD 106

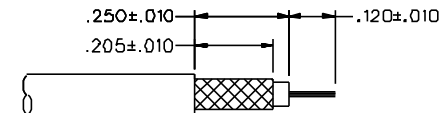

CABLE STRIP DIMENSIONS

4:1

CUSTOMER DRAWING

THIS DRAWING TO BE INTERPRETED PER ANS Y 14.5M - 1982

"μSTATION"

COMPANY CONFIDENTIAL

TOLERANCE UNLESS OTHERWISE SPECIFIED	DRAWN BY SWC	DATE 8-16-95	 299 Johnson Ave. P.O. Box 1732 Waseca, MN 56093-0832	
DECIMALS .XX	CHECKED BY SWC	DATE 11-16-95	TITLE JACK ASSEMBLY STRAIGHT CABLED, RG 316DS MCX	
.XXX+-.003	APPROVED BY TAK	DATE 1-2-96	CODE NO.	DRAWING NO.
MATL	APPROVED BY RJB	DATE 1-3-96	C - 133-3304-001/010	
FINISH	RELEASE DATE 1-3-96	SCALE 10:1	U/N INCH	SHEET 2 OF 2