

REVISIONS			
REV	DESCRIPTION	DATE	APPROVED
B	ECO #4226	08/22/01	A.D.M.
C	ECO #4263	09/24/01	A D M.

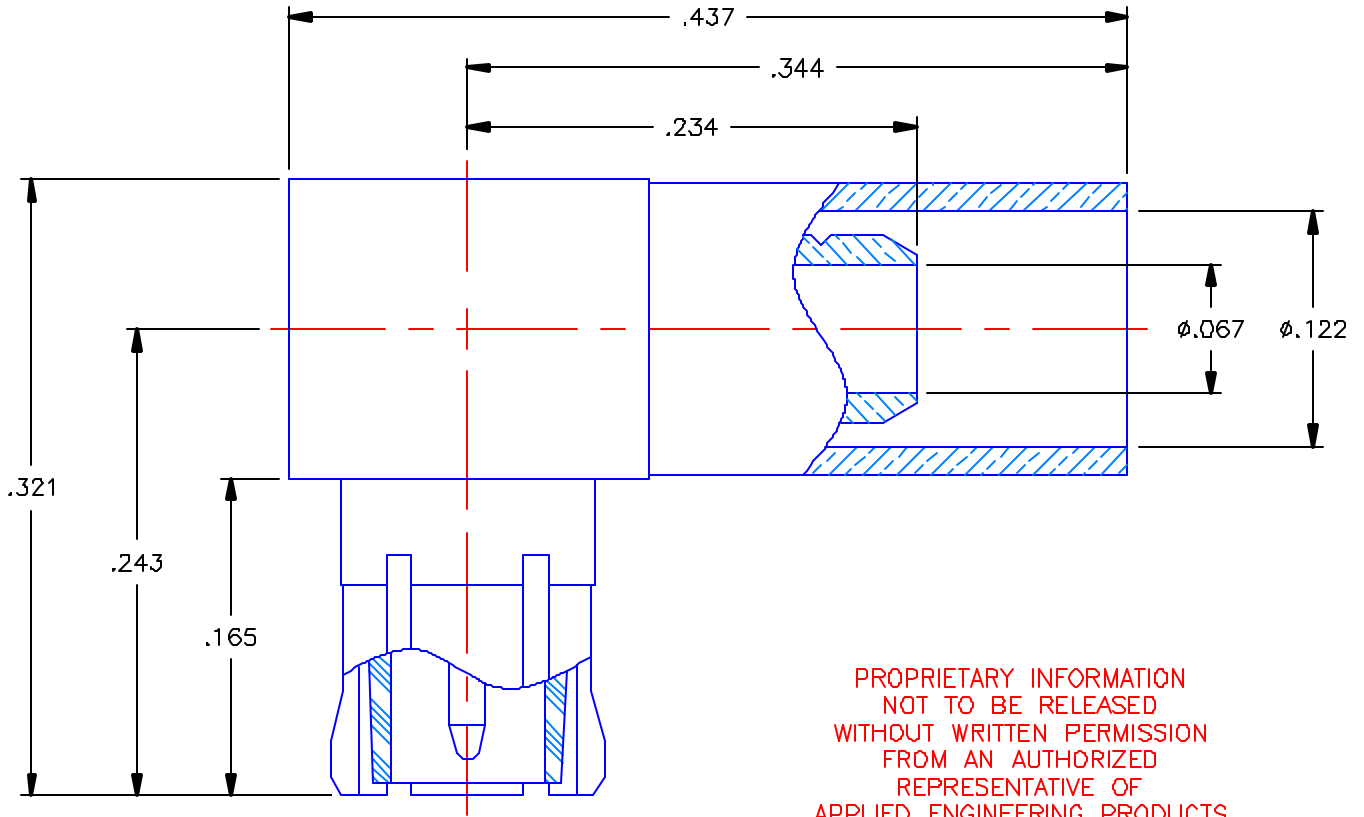

NOTES:

MATERIALS:

1. INTERFACE BODY = BERYLLIUM COPPER PER ASTM B196, ALLOY C17300, TEMPER TD04.
2. BODY, CONTACT, & CAP = BRASS PER ASTM B16, ALLOY C36000, TEMPER H02.
3. INSULATORS = VIRGIN WHITE TEFLON PER ASTM D1710, GRADE 1, TYPE I, CLASS "B".
4. CRIMP SLEEVE = SEAMLESS LOWLEAD BRASS TUBE, ALLOY 330, SOFT ANNEAL TEMPER, .025/.060 GRAIN SIZE OR SEAMLESS COPPER TUBE PER ASTM B75, TYPE C12000, TEMPER: LIGHT ANNEAL O50 EXCEPT YIELD STRENGTH.

FINISHES:

1. CONTACT = GOLD PLATE PER MIL-G-45204, TYPE II, CLASS O, GRADE C, OVER .00010 TO .00020 SULFAMATE NICKEL PER QQ-N-290.
2. ALL OTHER METAL PARTS = GOLD PLATE PER MIL-G-45204, TYPE II, GRADE C, .00001 MIN OVER STRESS FREE NICKEL PER QQ-N-290, .00002 TO .00004 THICK OVER A MIN COPPER STRIKE PER MIL-C-14550

UNLESS OTHERWISE SPECIFIED DIMENSIONS ARE IN INCHES TOLERANCES ON	DWN. A D.M.	DATE 08/21/01	 APPLIED ENGINEERING PRODUCTS 104 John W. Murphy Dr. New Haven, CT 06513
	CHKD:	DATE 08/22/01	
DECIMAL	ANGLE	D.N. 08/22/01	MCX RIGHT ANGLE PLUG CRIMP TYPE FOR RG-316 CABLE
		APVD: D.J.C. 08/22/01	
REFERENCE:	MATERIALS & FINISHES: SEE NOTES	SIZE A	FSCM NO. 19505
ORIGINATOR: E. WIDER DATE: 09/09/96		DWG NO. 8955-1521-003	REV C
		SCALE 10:1	SHEET 1 OF 1

8955-1521-003