

THIS DRAWING CONTAINS INFORMATION PROPRIETARY TO RF INDUSTRIES.  
 ANY UNAUTHORIZED USE OF THIS DRAWING IS EXPRESSLY PROHIBITED  
 WITHOUT WRITTEN PERMISSION FROM RF INDUSTRIES.  
 ANY VIOLATION IS PUNISHABLE UNDER U.S. COPYRIGHT LAWS.

ALL DIMENSIONS ARE REFERENCE ONLY

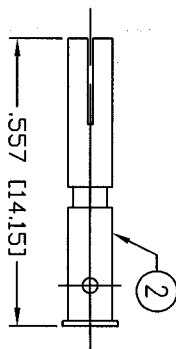

RECOMMENDED CRIMP DIE: .068

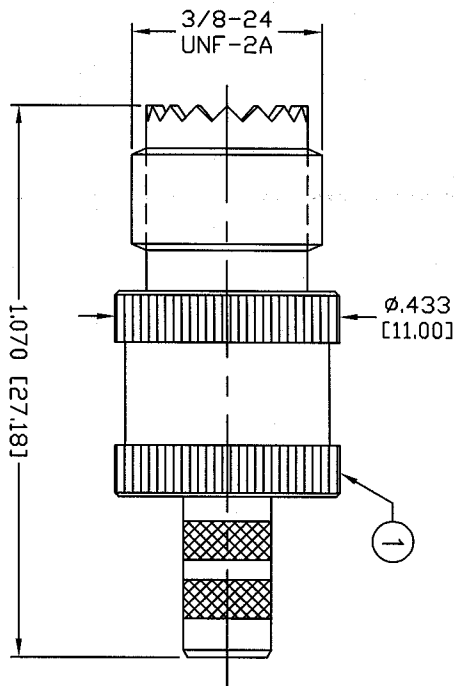
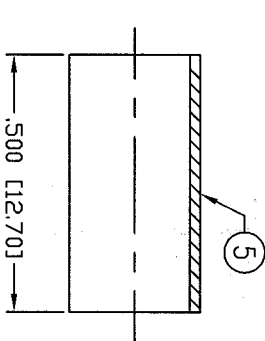

RECOMMENDED CRIMP DIE: .213

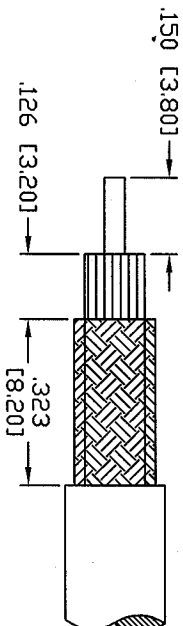

RECOMMENDED STRIPPING INSTRUCTIONS

**SPECIFICATIONS:**

IMPEDANCE: 50 Ohms  
 FREQUENCY RANGE: 0-2.5 GHz  
 VSWR: 1.25 MAX.  
 WORKING VOLTAGE: 335 V rms Max. @ Sea Level  
 INSULATION RESISTANCE: 5k M Ohms min.  
 TEMPERATURE RANGE: -65°C TO 165°C  
 FOR RG-58, 58A, 58C, 141, 141A, BELDEN 8240,  
 8259, 8262, 9201, 9203, 9310, 9311 & COMM/SCOPE 0268

#	DESCRIPTION	QTY	MATERIAL	FINISH	APPROVALS	DATE
1	BODY	1	BRASS	NICKEL, 80µ"		
2	CONTACT	1	BRASS	SILVER, 5µ"	000486	
3	INSULATOR	1	PIFE	---		
4	PRESS WASHER	1	BRASS	NICKEL, 80µ"		
5	FERRULE	1	BRASS	NICKEL, 80µ"		
6						
7						
8						
9						
10						
11						
12						
13						
14						

UNLESS OTHERWISE SPECIFIED:  
 1. REMOVE ALL BURRS  
 2. BREAK ALL CORNERS & EDGES .005 R. MAX.  
 3. CHAMFER 1ST & LAST THREADS 45°  
 4. SURFACE ROUGHNESS 63 FINISH MIL-STD-10  
 5. DIAMETERS ON COMMON CENTERS TO BE  
 CONCENTRIC WITHIN .002 T.I.R.  
 6. ALL DIMENSIONS ARE AFTER PLATING.

DIMENSIONS ARE IN INCHES  
 AND [MILLIMETERS]  
 UNLESS OTHERWISE NOTED  
 TOLERANCES ARE:  
 DECIMALS DIAMETER .xxx±.001 [.03]  
 .xxx±.003 [.08]  
 .xxx±.005 [.13]



7610 MIRAMAR RD  
 SAN DIEGO, CA 92126  
 (858) 549-6340  
 (858) 549-6345 FAX

## MINI UHF JACK, CRIMP

SIZE	CABLE GROUP	DWG NO.	REV
A	C	RFU-601-1	J

SCALE: NTS CAD FILE OUTLINE SHEET 1 OF 1

REV	DESCRIPTION	DWN	DATE	APPROVED
F	CHANGE DIELECTRIC INTERNAL DIMENSIONS / CHG STRIP INST	CZS	7/19/99	R. RICE
G	CHG DIELECTRIC ID, FERRULE ID & FER STUD CONFIG	CZS	1/19/00	J. D. MGR
H	ADDED 45 DEG. TO INSULATOR, ADDED UPPER & LOWER LIMITS	CZS	1/25/00	J. D. MGR
J	CHANGE STRIPPING DIM, DWG FORMAT / UPDATE SPECS	CZS	11/6/01	CZS

PART NO. **RFU-601-1**