

# ENVELOPE / ASSEMBLY DRAWING

008974

## SPECIFICATION CONTROL DRAWING

THIS DRAWING CONTAINS INFORMATION PROPRIETARY TO RF INDUSTRIES, LTD. ANY UNAUTHORIZED USE OF THIS DRAWING IS EXPRESSLY PROHIBITED. ANY VIOLATION IS PUNISHABLE UNDER U.S. COPYRIGHT LAWS.

REV	DESCRIPTION	DWN	DATE	APPROVED
A	ENGINEERING RELEASE	CZS	4/29/98	R. RICE

ALL DIMENSIONS ARE REFERENCE ONLY

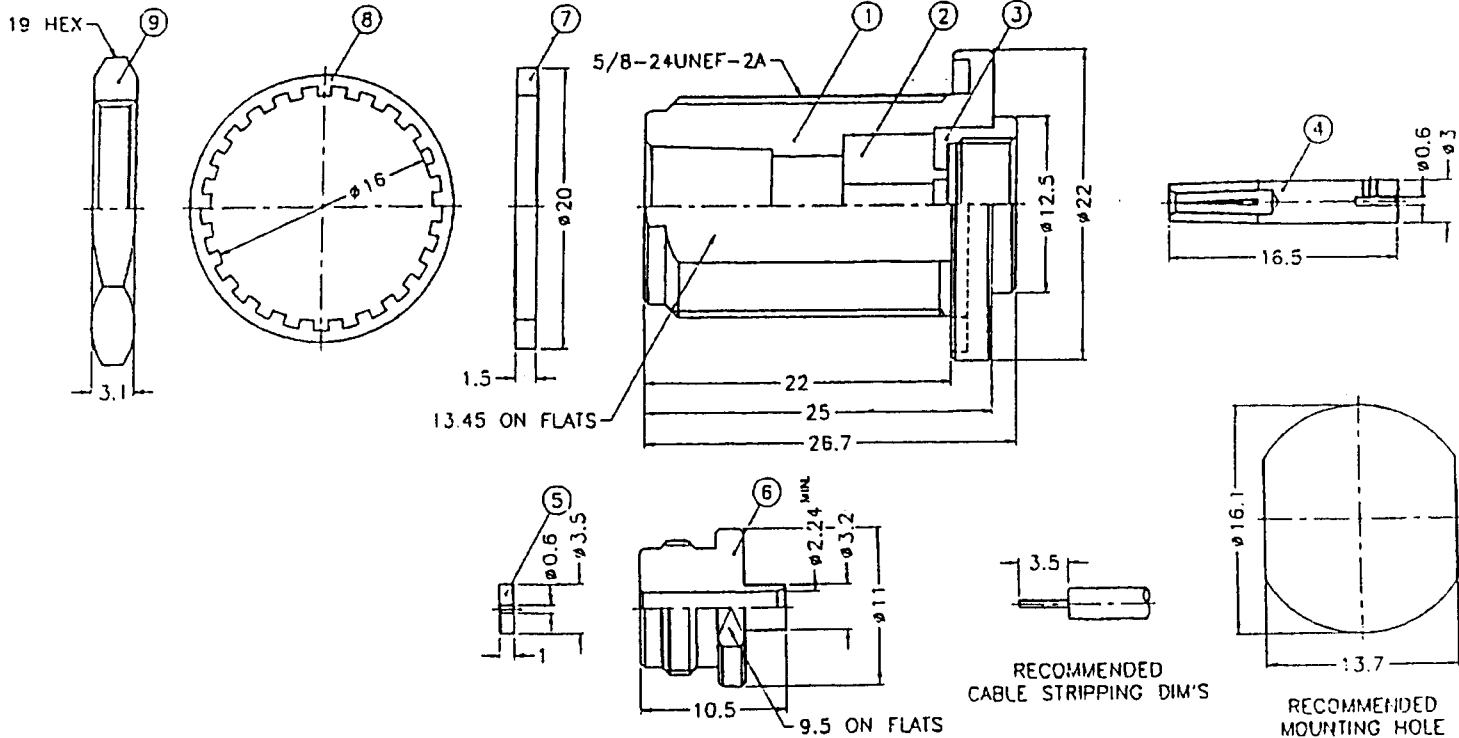

### SPECIFICATIONS:

IMPEDANCE: 50 OHMS  
FOR .085 SEMI RIGID, RG-405/U & BELDEN 1671A CABLE

ITEM	DESCRIPTION	QTY	MATERIAL	FINISH
9	HEX NUT	1	BRASS	NICKEL
8	LOCK WASHER	1	BRASS	NICKEL
7	GASKET	1	S.I. RUBBER	RED
6	SOLDER NUT	1	BRASS	GOLD
5	DIELECTRIC	1	BRASS	NONE
4	CONTACT	1	PHOS BRONZE	GOLD
3	PRESS FIT BODY	1	BRASS	NICKEL
2	DIELECTRIC	1	TEFLON	NONE
1	BODY	1	BRASS	NICKEL

DIMENSIONS ARE IN INCHES AND [MILLIMETERS]

UNLESS OTHERWISE NOTED TOLERANCES ARE:

DECIMALS DIAMETER

DRAWN	C. ZUNIGA	4/29/98
CHECKED	<i>[Signature]</i>	4/30/98
ORJ DRAWN	C. ZUNIGA	4/29/98
APPROVALS	DATE	

**RF connectors**  
DIVISION OF RF INDUSTRIES, LTD.

7610 MIRAMAR RD  
SAN DIEGO, CA 92126  
(619)549-6340  
(619)549-6345 FAX

## RFN-1022-SR1

N FEMALE BULHEAD, REAR MOUNT

SIZE	CABLE GROUP	DWG NO.	REV
A	SR1	8913	A
SCALE:	CAD FILE	SHEET 1 OF 1	
	13ARC B		