

N8105-0142

N Jack Crimp For Bulkhead 50Ω

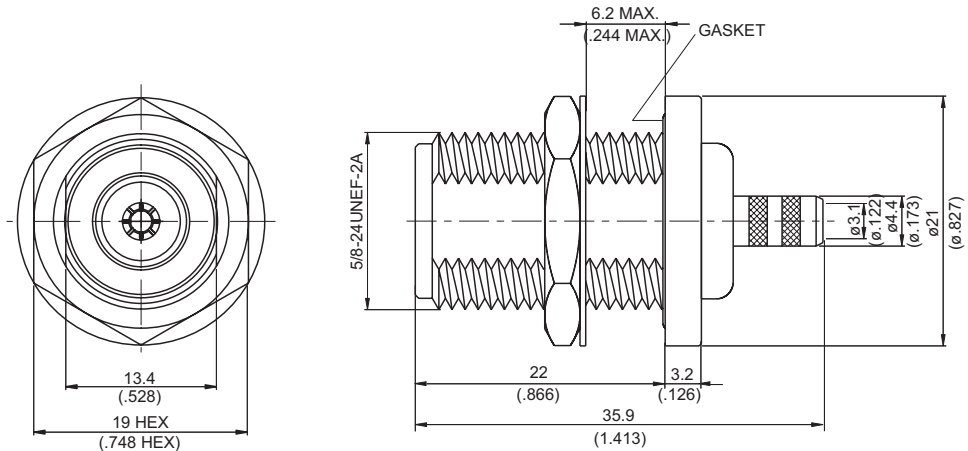

MOUNTING HOLE :

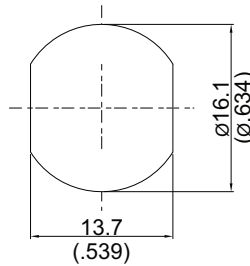

Parts	Material	Plating (Micro-inch)
Hex Nut	Brass	Tin-Zinc-Copper-Alloy 100 Over Copper 50
Lock Washer	Brass	Tin-Zinc-Copper-Alloy 100 Over Copper 50
Gasket	Silicon	
Ferrule	Brass	Tin-Zinc-Copper-Alloy 100 Over Copper 50
Contact Pin	Phosphor Bronze	Gold 5 Over Nickel 50 Over Copper 50
Barrel	Brass	Tin-Zinc-Copper-Alloy 100 Over Copper 50
Insulator	Teflon	
Body	Brass	Tin-Zinc-Copper-Alloy 100 Over Copper 50

Weight: 37.18 g

Suitable Cables: RG55, RG142, RG400, RG142-E

This part number complies with RoHS.

Notice: JYEBAO reserves the right to make modifications deemed appropriate.

## CABLE ASSEMBLY INSTRUCTION

N8105-0142

JYE BAO CO., LTD.

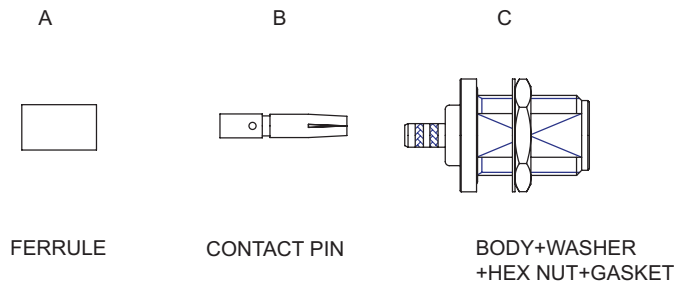
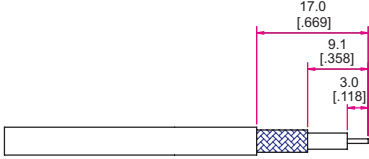
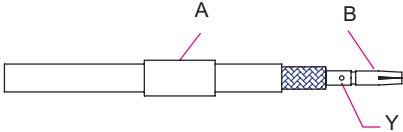
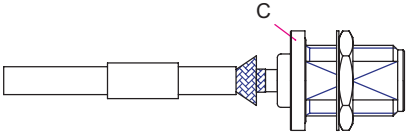
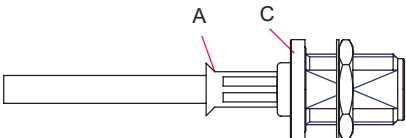

DIAGRAM	ASSEMBLY INSTRUCTION
	Step 1: STRIP AS SHOWN.
	Step 2: SLIDE FERRULE "A" OVER CABLE. Step 3: PUT PIN "B" ON CENTER CONDUCTOR AND SOLDER IN "Y".
	Step 4: LOOSEN BRAIDING AND SLIDE CONNECTOR "C" IN PLACE.
	Step 5: SLIDE FERRULE "A" TOWARDS THE CONNECTOR AND CRIMP.

This part number complies with RoHS.

Notice: JYEBAO reserves the right to make modifications deemed appropriate.