

ENVELOPE / ASSEMBLY DRAWING

008974

SPECIFICATION CONTROL DRAWING

THIS DRAWING CONTAINS INFORMATION PROPRIETARY TO RF INDUSTRIES, LTD. ANY UNAUTHORIZED USE OF THIS DRAWING IS EXPRESSLY PROHIBITED. ANY VIOLATION IS PUNISHABLE UNDER U.S. COPYRIGHT LAWS.

REV	DESCRIPTION	DWN	DATE	APPROVED
A	ENGINEERING RELEASE	CZS	7/20/99	R. RICE

ALL DIMENSIONS ARE REFERENCE ONLY

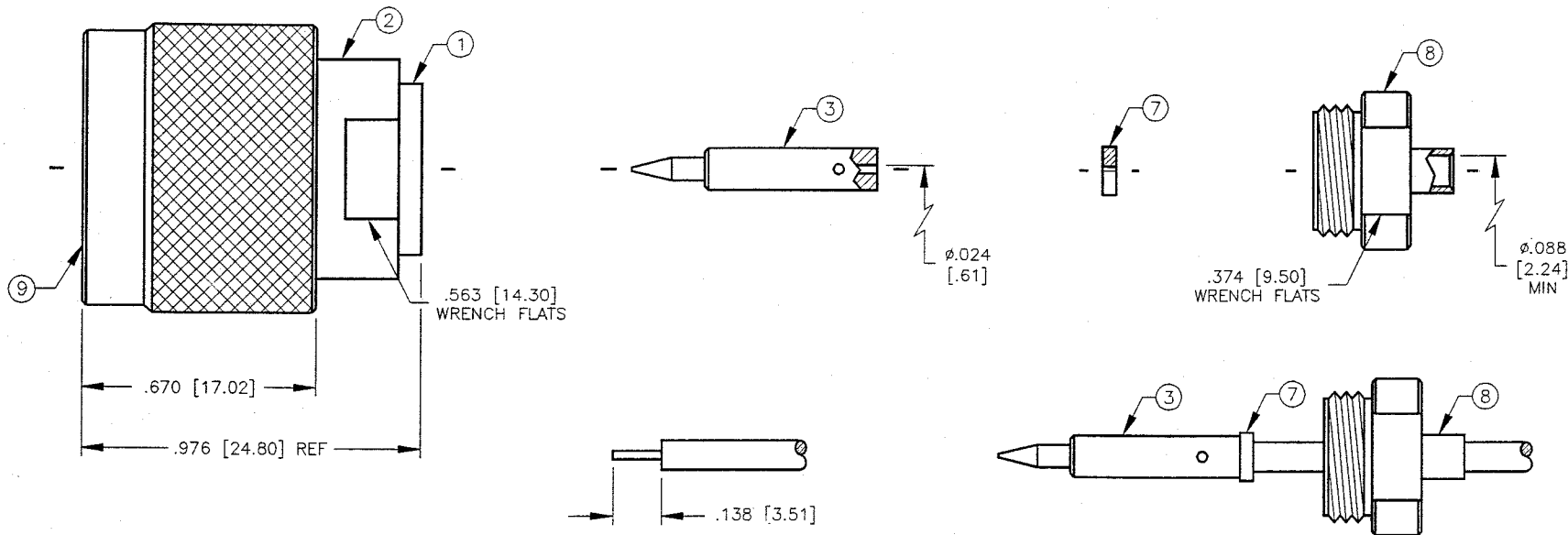

SUGGESTED STRIPPING INSTRUCTIONS

- 1.- SLIDE BACK NUT [#8] OVER CABLE & PLACE DIELECTRIC [#7] OVER CABLE CENTER CONDUCTOR BEFORE SOLDERING PIN
- 2.- SCREW BACK NUT INTO BODY
- 3.- SOLDER CABLE TO BACK NUT

SPECIFICATIONS:

IMPEDANCE: 50 OHMS
 WORKING VOLTAGE: 1000 VRMS @ SEA LEVEL
 FREQUENCY RANGE: 0-11 GHz
 FOR .085 SEMI RIGID, RG-405/U & BELDEN 1671A CABLE
 INTERFACE PER MIL-STD-348A, SECTION 304.1

DIMENSIONS ARE IN INCHES AND [MILLIMETERS]

UNLESS OTHERWISE NOTED TOLERANCES ARE:
 DECIMALS DIAMETER

RF connectors
 DIVISION OF RF INDUSTRIES, LTD.

7610 MIRAMAR RD
 SAN DIEGO, CA 92126
 (858) 549-6340
 (858) 549-6345 FAX

RFN-1005-1SR1

N MALE DIRECT SOLDER

ITEM	DESCRIPTION	QTY	MATERIAL	FINISH
9	SHELL	1	BRASS	NICKEL
8	BACK NUT	1	BRASS	GOLD
7	DIELECTRIC	1	TEFLON	NONE
6	RETAINING RING	1	BRASS	NONE
5	GASKET	1	S.I. RUBBER	RED
4	DIELECTRIC	1	TEFLON	NONE
3	PIN	1	BRASS	GOLD
2	BODY	1	BRASS	NICKEL
1	BODY	1	BRASS	NICKEL

DRAWN	C. ZUNIGA	7/20/99
CHECKED	<i>C. Zuniga</i>	7/21/99
OR DRAWN	C. ZUNIGA	7/20/99

SIZE	CABLE GROUP	DWG NO.	REV
A	SR1	9208	A