

N3100-9214	N Plug Crimp Right Angle	50Ω
------------	---------------------------------	------------

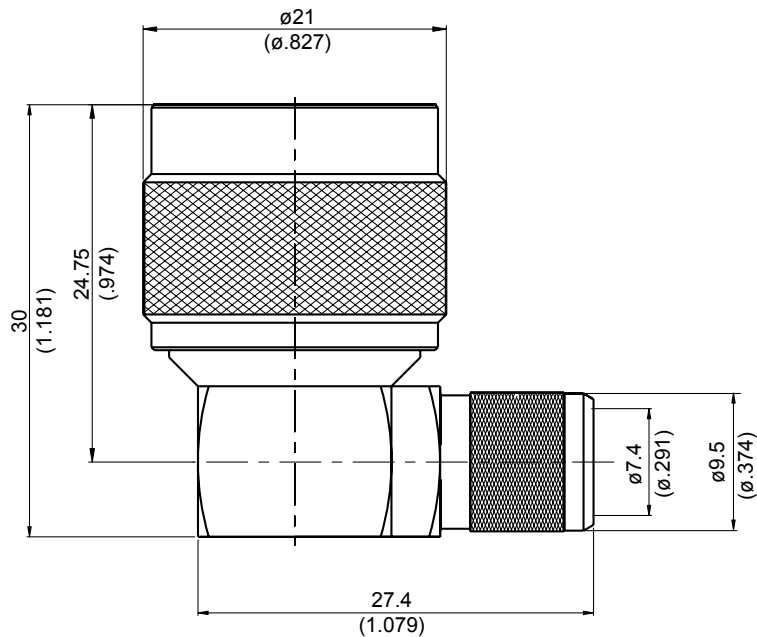

Parts	Material	Plating (Micro-inch)
Center Pin	Brass	Gold 5 Over Nickel 50 Over Copper 50
Barrel	Brass	Tin-Zinc-Copper-Alloy 100 Over Copper 50
Ferrule	Brass	Tin-Zinc-Copper-Alloy 100 Over Copper 50
Nut	Brass	Tin-Zinc-Copper-Alloy 100 Over Copper 50
Renbrock Ring	Brass	Tin-Zinc-Copper-Alloy 100 Over Copper 50
Gasket	Silicon	
Insulator	Teflon	
Contact Body	Brass	Tin-Zinc-Copper-Alloy 100 Over Copper 50
Body	Brass	Tin-Zinc-Copper-Alloy 100 Over Copper 50
Coupling Nut	Brass	Tin-Zinc-Copper-Alloy 100 Over Copper 50

Weight:
Suitable Cables: RG214

This part number complies with RoHS.

Notice: JYEBAO reserves the right to make modifications deemed appropriate.

CABLE ASSEMBLY INSTRUCTION

N3100-9214

JYE BAO CO., LTD.

N3100-9214

DATE

2014/04/29

REV

—

A

B

C

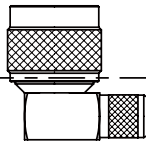

BODY

NUT

FERRULE

DIAGRAM

ASSEMBLY INSTRUCTION

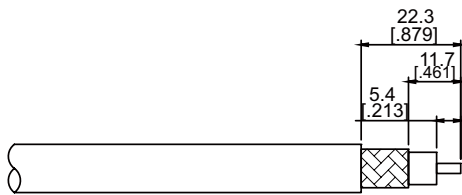

Step 1: STRIP AS SHOWN.

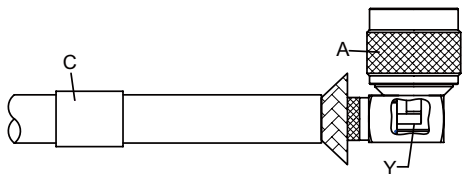

Step 2: SLIDE FERRULE " C " OVER CABLE.
 Step 3: WRAP THE BRAIDING UPWARDS.
 Step 4: SLIDE CENTER CONDUCTOR ON THE CONTACT PIN OF CONNECTOR " A " AND SOLDER IN " Y ".



Step 5: SLIDE FERRULE " C " TOWARDS THE CONNECTOR " A " AND CRIMP.
 (USE 10.7mm/0.421inch HEX SECTION OF INSERT-C)

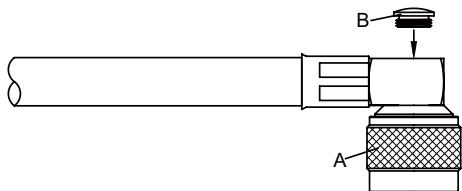

Step 6: SCREW NUT " B " ON THE CONNECTOR " A ".

This part number complies with RoHS.

Notice: JYEBAO reserves the right to make modifications deemed appropriate.