

CAD DRAWING - NO MANUAL REVISIONS

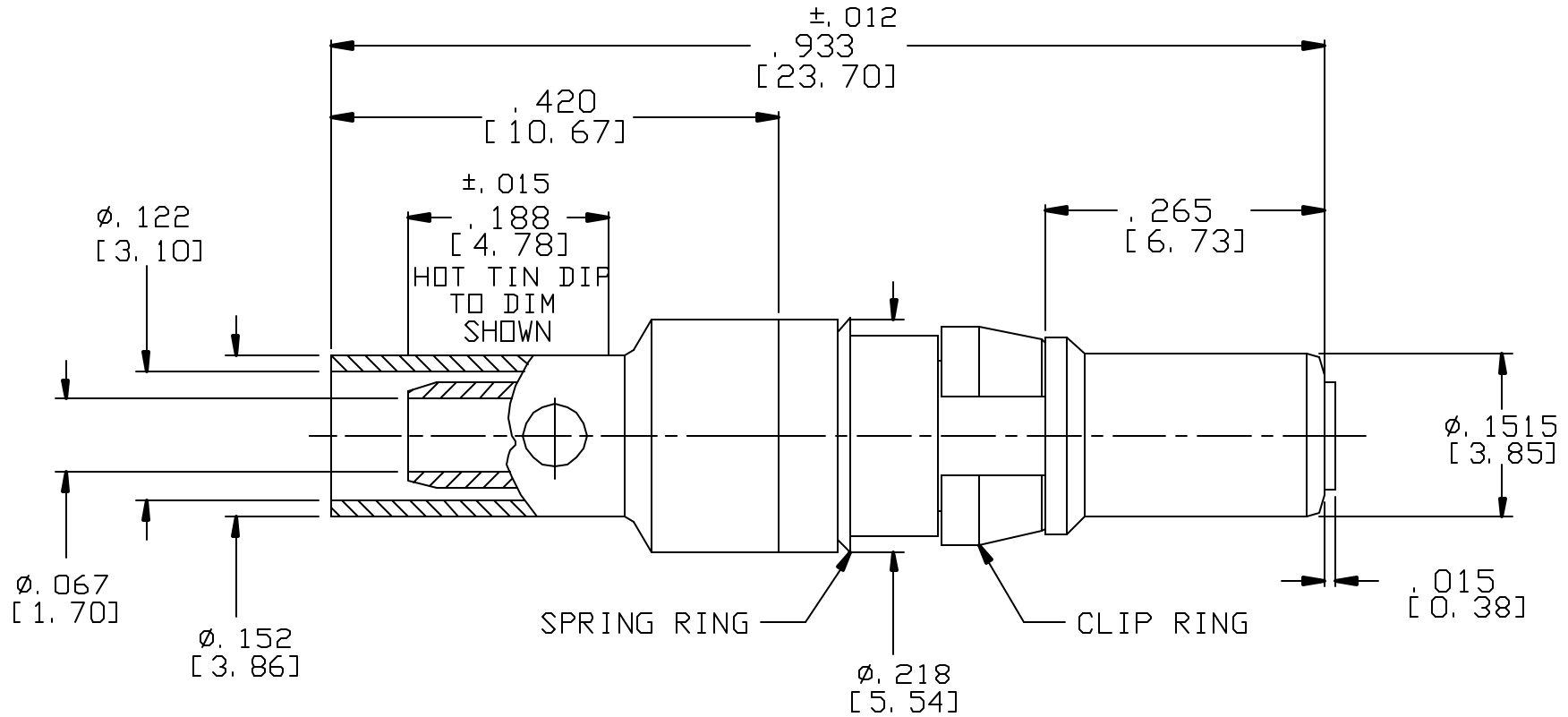

NOTES:

- DESIGN AND INTERFACE PER I. D. S. -24.
- USE WITH RG 174, 179, 188 & 316 CABLES.

				<p><b>PALCO CONNECTOR</b></p> <p>22 GREAT HILL RD., NAUGATUCK, CT 06770</p> <p>UNLESS OTHERWISE SPECIFIED, PALCO WORKMANSHIP STANDARDS APPLY</p> <p>TOLERANCES ON: DECIMALS: XX <math>\pm .01</math> .XXX <math>\pm .005</math> ANGLES <math>\pm 1/2^\circ</math> 32</p> <p>DIMENSIONS IN INCHES OR (METRIC) DO NOT SCALE PRINTS</p>	<p>DRAWN</p> <p>MY</p>	<p>CHECKED</p> <p>HN</p>	<p>ENGINEER</p> <p>MY</p>	<p>APPROVED</p> <p>HN</p>	<p>FSCM</p> <p>58167</p>
E	PER ECN 6835	12/18/02	HN			<p>DESCRIPTION STRAGHT PLUG PDM (50 OHM)</p>			
D	PER ECN 5902	02/27/01	HN			<p>DATE</p> <p>02/15/82</p>	<p>DRAWING NO.</p> <p>24-0020-0670</p>	<p>PLATING OPT.</p> <p>A, B, C, D</p>	
C	PER ECN 4359	02/04/98	HN						
B	PER ECN 1485	07/24/90	HN						
REV.	DESCRIPTION	DATE	APPR.	MAT'L CATALOG ITEM					