

- 1.0 PERFORMANCE:
 1.1 FREQUENCY RANGE DC-27 GHz
 1.2 VSWR TYP < 1.25 THRU 20GHz
 < 1.07 (DC-11 GHz)
 < 0.85+.02F (11-20 GHz)
 1.3 SYSTEM IMPEDANCE 50 OHMS
 1.4 DWV: 1000 Vrms @ 60 Hz (SEA LEVEL)
 1.5 VOLTAGE RATING: 335 Vrms (SEA LEVEL)
 1.6 TEMP RANGE: -65 / +165 °C

- 2.0 MATERIALS
 2.1 SOCKET CONTACT: BeCu
 2.2 BODY: SS 303
 2.3 INSULATOR: PTFE
 3.0 FINISHES
 3.1 CONTACTS: MINIMUM PLATE OF .000050 GOLD
 OVER .000080 NICKEL
 3.2 BODY: PASSIVATED

- 4.0 MECHANICAL
 4.1 INTERFACES PER MIL-STD-348
 4.2 SOCKET MATING CHARACTERISTICS:
 INSERTION FORCE: ϕ .013, 20 OZ TYP, 30 OZ MAX
 WITHDRAWAL FORCE: ϕ .011, 0.5 OZ MIN
 4.4 CONTACT RETENTION: 4 LBS MIN
 4.5 DURABILITY: 500 CYCLES

DO NOT SCALE DRAWING

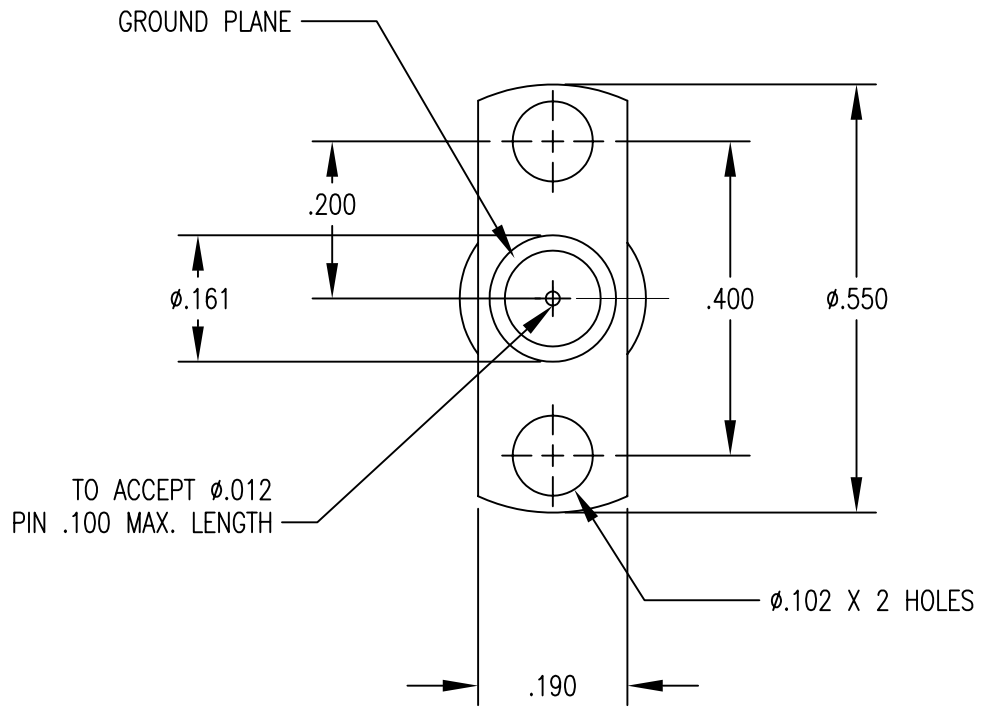
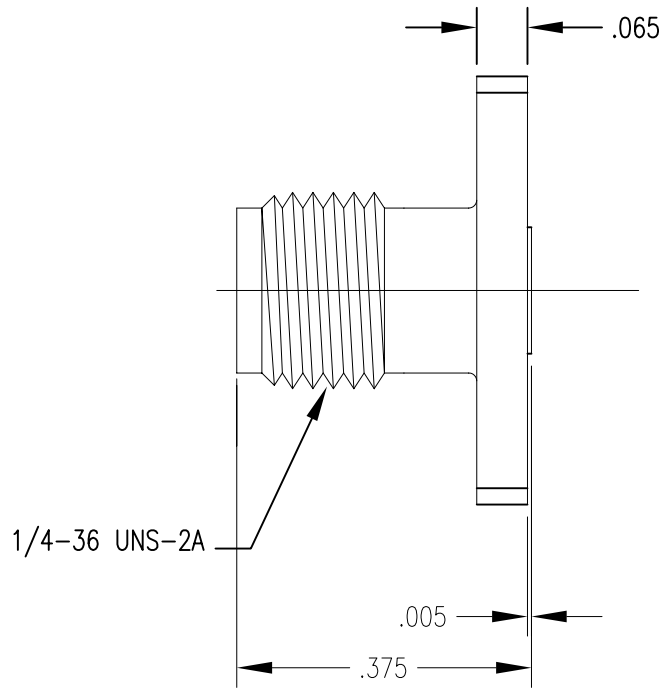

P/N: 1206-52-PJ

Rev.	Revisions	Disp.	Date	Dwn.	Appd.
D	UPDATE PERFORMANCE PER TEST RESULTS	USE	9/7/05	WJ	FSH
C	CHD NOTES 1.1, 1.2 & 4.2,	RWK	4/4/05	RF	FSH
B	VSWR WAS 1.15 / INSERTION FORCE WAS 20 OZ MAX	RWK	11/11/04	FSH	FSH
A	ORIGINAL	NEW	07/28/04		
RECOM.	STOCK SIZE	FT/M	PCS	Ref.:	SK
REMOVE ALL BURRS AND SHARP EDGES .005 MAX.		INTERPRET PER ASME Y14.5M-1994			

THIS DRAWING CONTAINS CONFIDENTIAL INFORMATION PROPRIETARY TO SAN-TRON INC. IT MUST NOT BE REPRODUCED OR DISCLOSED TO OTHERS OR USED IN ANY OTHER WAY, IN WHOLE OR PART EXCEPT AS AUTHORIZED IN WRITING BY SAN-TRON INCORPORATED.

UNLESS OTHERWISE SPECIFIED:
 ALL DIMENSIONS ARE IN INCHES.
 ALL DIMENSIONS ARE AFTER PLATING.
 .XXX= ±.005 ALL MACHINED SURFACES \sqrt{R} MAX.
 .XX= ±.01 ANG. ±1/2° FRACTIONAL= ±1/64
 [◎].004 MAX. TIR. [⊥] AXIS .001

THIRD ANGLE PROJECTION

DWN	RF	07/28/04
CHKD		
APPR	FSH	07/28/04

SAN-TRON, INC.
 4 NEWBURYPORT TPK. IPSWICH MA USA 01938
 TEL: 978 - 356 -1585 FAX: 978 - 356 -1573
 WWW. santron.com E MAIL: santron@santron.com

TITLE SMA RECEPTACLE, STRAIGHT, FEMALE, 2 HOLE FLANGE, FIELD REPLACEABLE (ϕ .012 PIN)

MATERIAL: SEE NOTE 2.0 FINISH: SEE NOTE 3.0

CAGE CODE: 50896 DWG NO. OL-1206-52-1

SCALE X:X