

N3100AS-9L600

Stainless N Plug Crimp Right Angle

50Ω

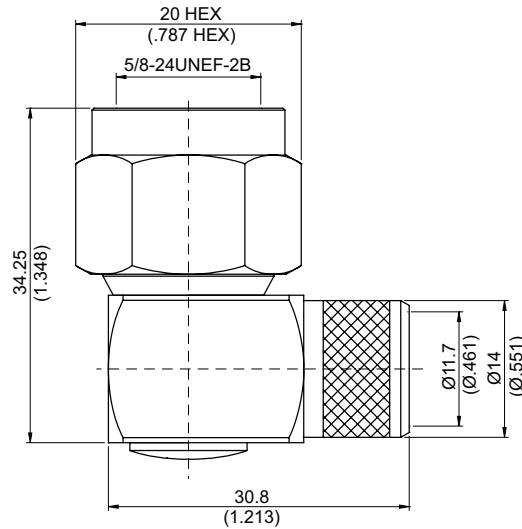

Parts	Material	Plating(Micro-inch)
Ferrule	Brass	Tin-Zinc-Copper-Alloy 100 Over Copper 50
Nut	Brass	Tin-Zinc-Copper-Alloy 100 Over Copper 50
Retainer Ring	Brass	Tin-Zinc-Copper-Alloy 100 Over Copper 50
Gasket	Silicon	
Contact Pin	Phosphor Bronze	Gold 5 Over Nickel 50 Over Copper 50
Insulator	Teflon	
Barrel	Stainless Steel	Passivated
Contact Body	Stainless Steel	Passivated
Body	Stainless Steel	Passivated
Coupling Nut	Stainless Steel	Passivated

Weight:

Suitable Cables: JBY600,LMR600

This part number complies with RoHS.

Notice: JYEBAO reserves the right to make modifications deemed appropriate.

CABLE ASSEMBLY INSTRUCTION

N3100AS-9L600

JYE BAO CO., LTD.

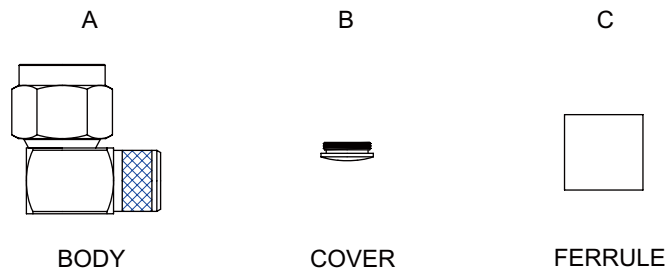

DIAGRAM	ASSEMBLY INSTRUCTION
	<p>Step 1: STRIP AS SHOWN. Step 2: SHARPEN CENTER CONDUCTOR TIP.</p>
	<p>Step 3: SLIDE FERRULE " C " OVER CABLE . Step 4: WRAP THE BRAIDING UPWARDS. Step 5: SLIDE CENTER CONDUCTOR ON THE CONTACT PIN OF CONNECTOR " A " AND SOLDER IN " Y " .</p>
	<p>Step 6: SLIDE FERRULE " C " TOWARDS THE CONNECTOR " A " AND CRIMP .</p>
	<p>Step 7: FINALLY SCREW " B " ON THE CONNECTOR BODY " A " .</p>

This part number complies with RoHS.

Notice: JYEBAO reserves the right to make modifications deemed appropriate.