

***** THIS DRAWING AND ITS CONTENTS ARE THE SOLE PROPERTY OF PRECISION CONNECTOR INC. AND ARE SUBJECT TO CHANGE WITHOUT NOTICE UNLESS OTHERWISE SPECIFIED *****

REV.	DESCRIPTION	DATE	BY	APPVD
A	INITIAL RELEASE	09/11/09	MJK	MJK

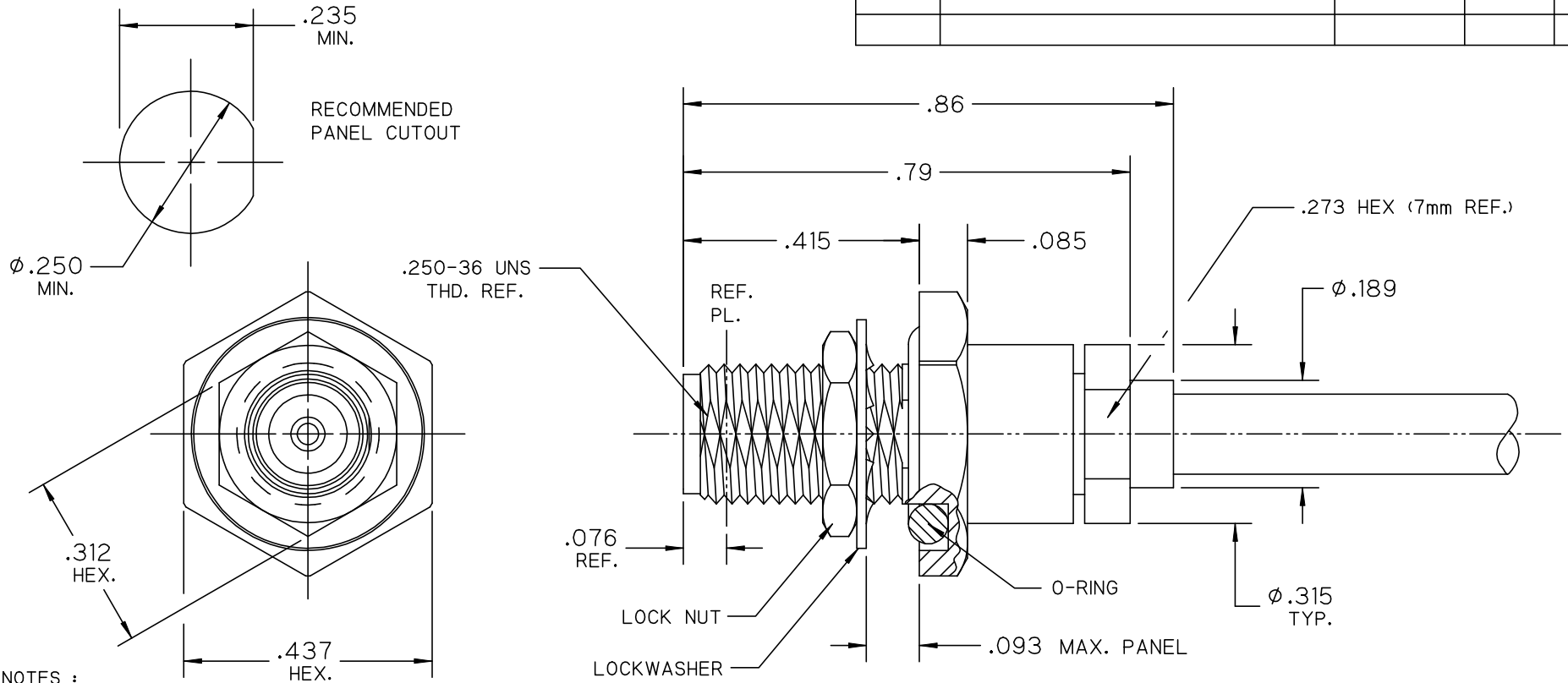

NOTES :

1.0 MATERIALS:

- 1.1 BODY, BUSHING & LOCK NUT: STEEL, CORROSION RESISTANT PER ASTM-A582, UNS NO. S30300.
- 1.2 CLAMP NUT: BRASS PER ASTM-B16, UNS NO. C36000.
- 1.3 LOCKWASHER: STEEL, CORROSION RESISTANT PER ASTM-A313, UNS NO. S30200.
- 1.4 CENTER COND.: BERYLLIUM COPPER PER ASTM-B196, UNS C17300.
- 1.5 O-RING: SILICONE RUBBER PER A-A-59588.
- 1.6 DIELECTRIC BEAD: POLYCHLOROTRIFLUOROETHYLENE (PCTFE) PER ASTM-D1430-95. (KEL-F)

2.0 FINISHES:

- 2.1 BODY, BUSHING, LOCKWASHER & LOCK NUT: PASSIVATE PER SAE-AMS-2700.
 - 2.2 CENTER CONTACT & CLAMP NUT: GOLD PLATE PER ASTM-B488, 50 MICROINCHES MIN. THK. OVER ELECTROLYTIC NICKEL PLATE PER ASTM-B689, 50 MICROINCHES MIN. THK.
 - 2.3 O-RING & DIELECTRIC BEAD: NONE.
- 3.0 INTERFACE : 3.5mm SOCKET PER IEEE P287/D3, FIGURE F.4 (GPC - LESS UNDERCUT). INTERFACE CONTACT RECESSION HELD TO .000/.003.



TOLERANCES UNLESS OTHERWISE SPECIFIED	DRAWN BY: MJK	TITLE : OUTLINE DRAWING, 3.5mm BULKHEAD JACK. SOLDER CLAMP NUT FOR RG-402 CABLE			
	DATE: 09/11/09	CAGE CODE	SCALE	SHEET NO.	DRAWING NUMBER
.XX ± .02	4MJR5	4:1	1 OF 1	3382-0L	A
.XXX ± .005					
.XXXX ± .0005					
ANGLES ± 2°					