

\*\*\*\*\* THIS DRAWING AND ITS CONTENTS ARE THE SOLE PROPERTY OF PRECISION CONNECTOR INC. AND ARE SUBJECT TO CHANGE WITHOUT NOTICE UNLESS OTHERWISE SPECIFIED \*\*\*\*\*

REV.	DESCRIPTION	DATE	BY	APPVD
A	INITIAL RELEASE	03/10/08	MJK	MJK

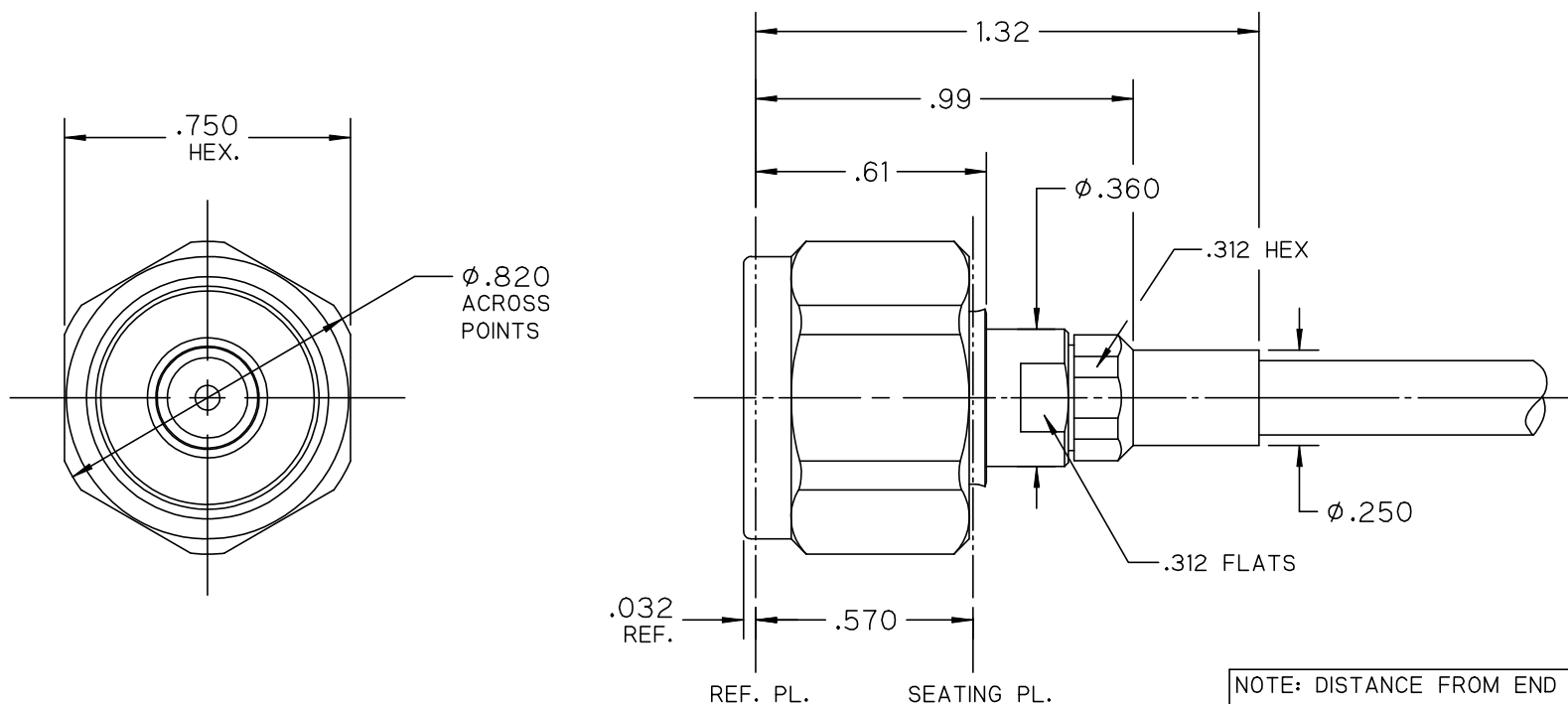

NOTES :

1.0 MATERIALS:

- 1.1 BODY, COUPLING & CLAMP NUTS: STEEL, CORROSION RESISTANT PER ASTM-A582, UNS NO. S30300.
- 1.2 CENTER COND.: BERYLLIUM COPPER PER ASTM-B196, UNS C17300.
- 1.3 SOLDER FERRULE: BRASS PER ASTM-B16, UNS C36000.
- 1.4 GASKET: SILICONE RUBBER PER A-A-59588.
- 1.5 INSULATOR: PTFE FLUOROCARBON PER ASTM-D1710.
- 1.6 CABLE STOP: POLYETHERIMIDE THERMOPLASTIC (ULTEM 1000) PER ASTM-D5205.

2.0 FINISHES:

- 2.1 CENTER CONTACT & SOLDER FERRULE: GOLD PLATE PER ASTM-B488, 50 MICROINCHES MIN. THK. OVER ELECTROLYTIC NICKEL PLATE PER ASTM-B689 50 MICROINCHES MIN. THK.
  - 2.2 BODY, COUPLING & CLAMP NUTS: PASSIVATE PER SAE-AMS-2700.
  - 2.3 GASKET & DIELECTRICS: NONE.
- 3.0 INTERFACE: TYPE N PLUG PER PCI INTERFACE SPECIFICATION PCI-PNP-TL.

NOTE: DISTANCE FROM END OF CABLE CENTER COND. TO REF. PL. IS .440



TOLERANCES UNLESS OTHERWISE SPECIFIED	DRAWN BY: MJK	TITLE : OUTLINE DRAWING, N PLUG, SOLDER CLAMP FOR HARBOUR SB142 CABLE			
	DATE: 03/10/08	CAGE CODE	SCALE	SHEET NO.	DRAWING NUMBER
.XX ± .02	<b>4MJR5</b>	<b>5:1</b>	1 OF 1	3239-0L	REV
.XXX ± .005					A
.XXXX ± .0005					
ANGLES ± 2°					