

PROPRIETARY INFORMATION
 NOT TO BE RELEASED
 WITHOUT WRITTEN PERMISSION
 FROM AN AUTHORIZED
 REPRESENTATIVE OF
 APPLIED ENGINEERING PRODUCTS

REVISIONS			
REV.	DESCRIPTION	DATE	APPROVED
A	INITIAL RELEASE	08/16/07	K.P.

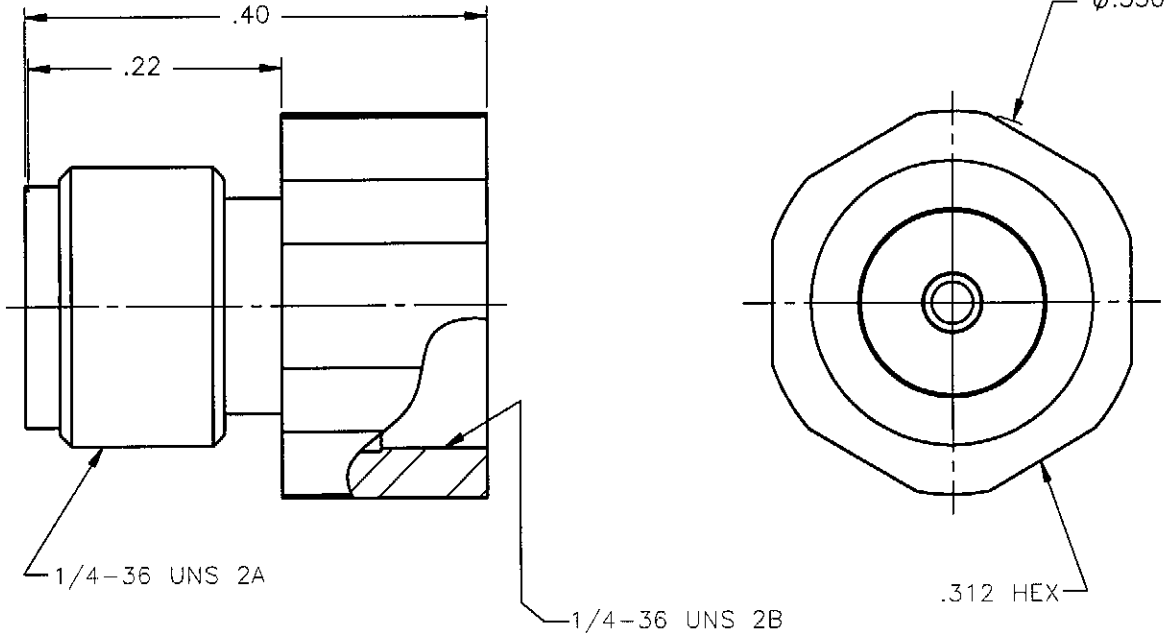

NOTES:

MATERIALS:

1. BODY = STAINLESS STEEL PER ASTM A582, ALLOY 303, CONDITION "A".
2. INSULATOR = VIRGIN WHITE TEFLON PER ASTM D1710, GRADE 1, TYPE I, CLASS "B".
3. CONTACT = BERYLLIUM COPPER PER ASTM B196, ALLOY C17300, TEMPER TD04.

FINISHES:

1. BODY = PASSIVATE PER QQ-P-35, TYPE VI.
2. CONTACT = GOLD PLATE PER MIL-G-45204, TYPE II, CLASS 1, GRADE C, OVER .00010 TO .00020 STRESS FREE SULFAMATE NICKEL PER QQ-N-290.

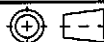
UNLESS OTHERWISE SPECIFIED DIMENSIONS ARE IN INCHES TOLERANCES ON	DWN: K.P.	DATE 08/16/07	 APPLIED ENGINEERING PRODUCTS 104 John W. Murphy Dr. New Haven, CT 06513		
	CHKD: D.N.	DATE 08/16/07			
DECIMAL	ANGLE	APVD: J.M.	DATE 08/16/07	SMA STRAIGHT FIELD REPLACEABLE JACK	
REFERENCE:	MATERIALS & FINISHES: SEE NOTES	SIZE A	FSCM NO. 19505		
ORIGINATED: K.P. DATE: 08/16/07	SCALE 8:1		THIRD ANGLE PROJECTION 		SHEET 1 OF 1

9666-9113-000