

SHV3200B-0058

SHV Plug Clamp

50Ω

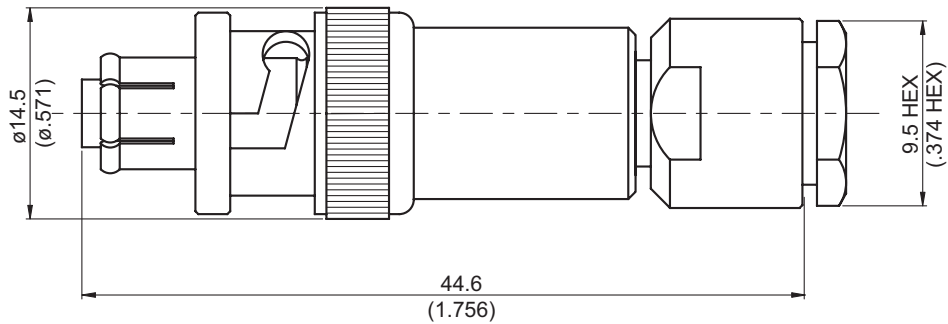

Parts	Material	Plating(Micro-inch)
Hex Nut	Brass	Tin-Zinc-Copper-Alloy 100 Over Copper 50
Contact Pin	Phosphor Bronze	Gold 5 Over Nickel 50 Over Copper 50
Gasket	Silicone	
Washer	Brass	Tin-Zinc-Copper-Alloy 100 Over Copper 50
Spring	SK5	Tin-Zinc-Copper-Alloy 100 Over Copper 50
Insulator	Teflon	
Body	Brass	Tin-Zinc-Copper-Alloy 100 Over Copper 50
Coupling Nut	Brass	Tin-Zinc-Copper-Alloy 100 Over Copper 50

Weight: 22.98 g

Suitable Cables:RG58, JBY195, RG55, RG142, RG400, RG142-E, RG223

This part number complies with RoHS.

Notice: JYEBAO reserves the right to make modification deemed appropriate.

CABLE ASSEMBLY INSTRUCTION

SHV3200B-0058

JYE BAO CO., LTD.

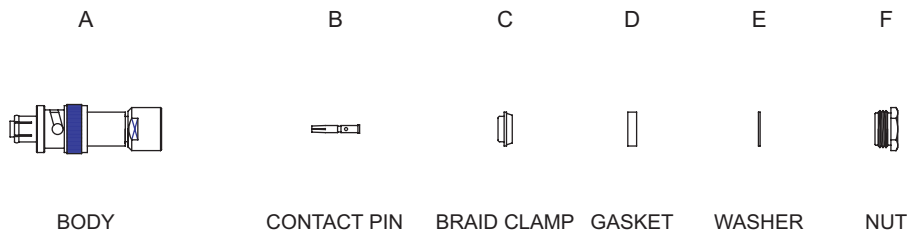
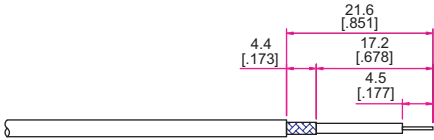
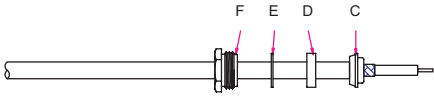
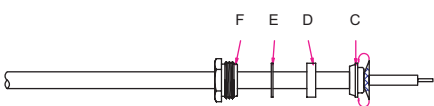
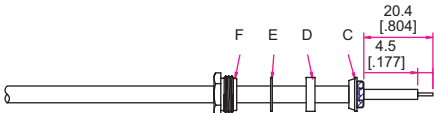
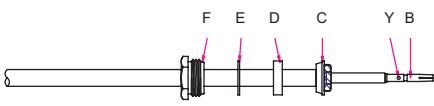
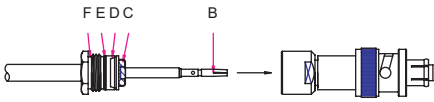

DIAGRAM	ASSEMBLY INSTRUCTION
	Step 1: STRIP AS SHOWN .
	Step 2: SLIDE BRAID CLAMP " C " ,GASKET " D " , WASHER " E " AND NUT " F " OVER CABLE .
	Step 3: WRAP THE BRAIDING OVER " C " .
	Step 4: STRIP AS SHOWN .
	Step 5: PUT CONTACT PIN " B " ON CENTER CONDUCTOR AND SOLDER IN " Y " .
	Step 6: FINALLY SCREW " F " ON THE CONNECTOR BODY " A " .

This part number complies with RoHS.

Notice: JYEBAO reserves the right to make modifications deemed appropriate.