

SHV3200-9058

SHV Plug Clamp Right Angle 50Ω

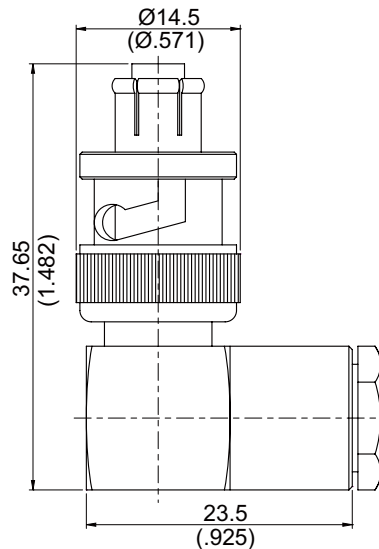

Parts	Material	Plating(Micro-inch)
Ferrule	Brass	Tin-Zinc-Copper-Alloy 100 Over Copper 50
Nut	Brass	Tin-Zinc-Copper-Alloy 100 Over Copper 50
Insulator	Teflon	
Hex Nut	Brass	Tin-Zinc-Copper-Alloy 100 Over Copper 50
Washer	Brass	Tin-Zinc-Copper-Alloy 100 Over Copper 50
Gasket	Silicon	
Braid Clamp	Brass	Tin-Zinc-Copper-Alloy 100 Over Copper 50
Spring	SK5	Tin-Zinc-Copper-Alloy 100 Over Copper 50
Contact Pin	Phosphor Bronze	Gold 4 Over Nickel-Phosphorous Alloy 80 Over Copper 20
Body	Brass	Tin-Zinc-Copper-Alloy 100 Over Copper 50
Contact Body	Brass	Tin-Zinc-Copper-Alloy 100 Over Copper 50
Coupling Nut	Brass	Tin-Zinc-Copper-Alloy 100 Over Copper 50

Weight:

Suitable Cables: RG58, JBY195, RG55, RG142, RG400, RG142-E

This part number complies with RoHS.

Notice: JYEBAO reserves the right to make modification deemed appropriate.

CABLE ASSEMBLY INSTRUCTION

SHV3200-9058

JYE BAO CO., LTD.

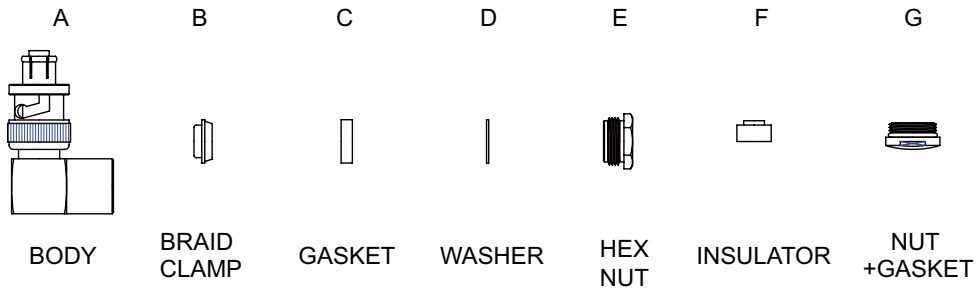
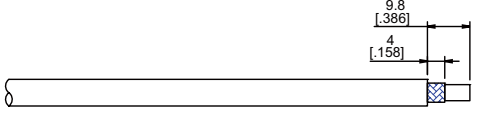
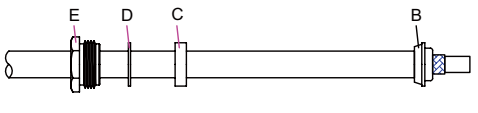
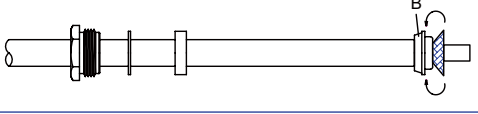
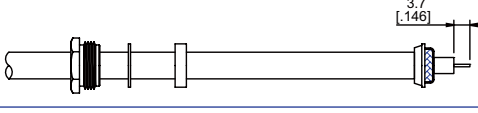
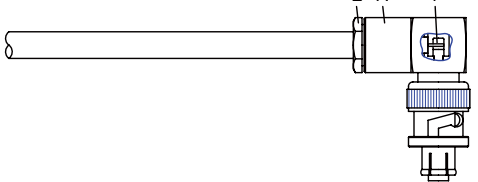
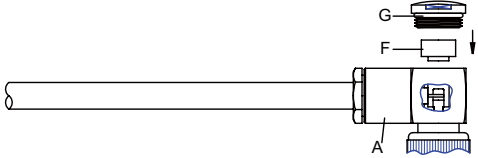

DIAGRAM	ASSEMBLY INSTRUCTION
	Step 1: STRIP AS SHOWN.
	Step 2: SLIDE BRAID CLAMP " B ", GASKET " C ", WASHER " D " AND HEX NUT " E " OVER CABLE.
	Step 3: WRAP THE BRAIDING OVER " B " .
	Step 4: STRIP AS SHOWN .
	Step 5: SCREW HEX NUT " E " ON THE CONNECTOR BODY " A " AND SOLDER IN " Y " .
	Step 6: SLIDE INSULATOR " F " INTO CONNECTOR BODY " A " AND SCREW NUT " G " ON THE CONNECTOR BODY " A " .

This part number complies with RoHS.

Notice: JYEBAO reserves the right to make modifications deemed appropriate.