

REVISIONS			
REV.	DESCRIPTION	DATE	APPROVED
A	INITIAL RELEASE	08/28/15	N.D.

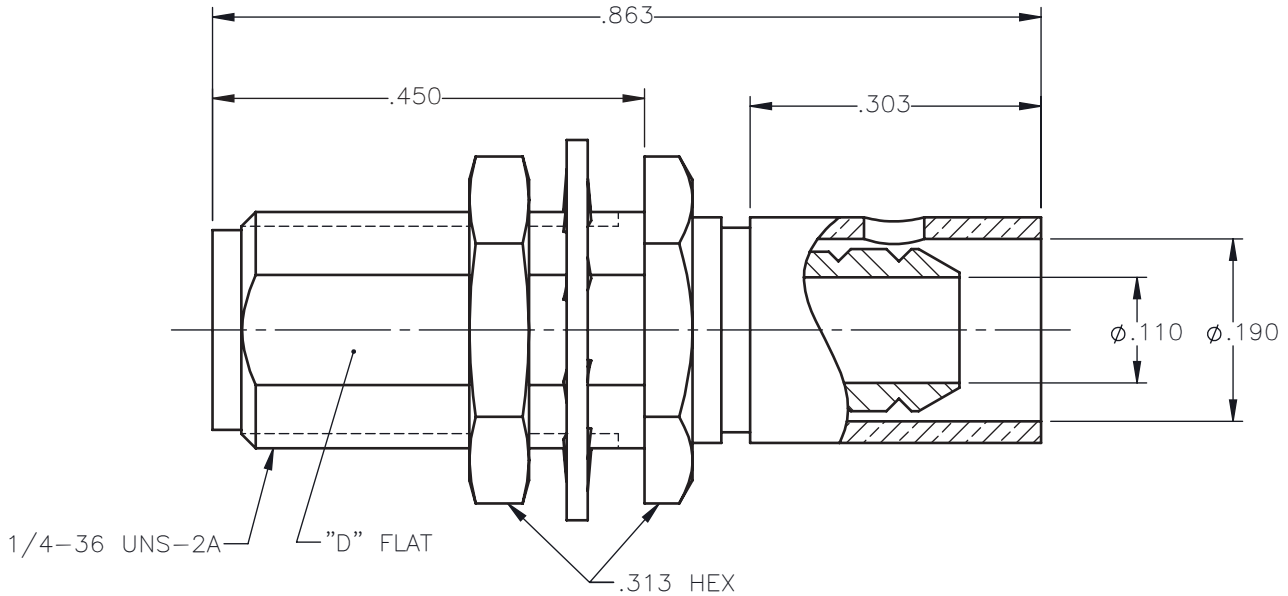

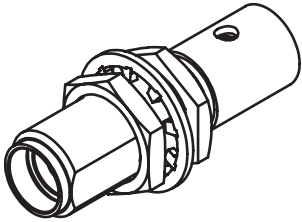

NOTES:

MATERIALS:

1. BODY & NUT = STAINLESS STEEL PER ASTM A582, ALLOY 303, CONDITION "A".
2. INSULATOR = VIRGIN WHITE TEFLON PER ASTM D1710, GRADE 1, TYPE I, CLASS "B".
3. CONTACT = BERYLLIUM COPPER PER ASTM B196, ALLOY C17300, TEMPER TD04.
4. LOCKWASHER = PHOSPHOR BRONZE PER ASTM B139, COPPER ALLOY C53400, TEMPER H04.
5. CRIMP SLEEVE = SEAMLESS LOWLEAD BRASS TUBE, ALLOY 330, SOFT ANNEAL TEMPER, .025/.060 GRAIN SIZE OR SEAMLESS COPPER TUBE PER ASTM B75, TYPE C12000, TEMPER: LIGHT ANNEAL O50 EXCEPT YIELD STRENGTH.
6. SHRINK SLEEVE = THERMOFIT SCL, BLACK (NOT SHOWN)

FINISHES:

1. BODY & NUT = GOLD PLATE PER ASTM B488-01, TYPE II, 30 μ in MIN, GRADE C, OVER 50 TO 100 μ in STRESS FREE NICKEL PER QQ-N-290.
2. CONTACT = GOLD PLATE PER ASTM B488-01, TYPE II, 50 μ in MIN, GRADE C, OVER 100 TO 200 μ in STRESS FREE SULFAMATE NICKEL PER QQ-N-290.
3. ALL OTHER METAL PARTS = GOLD PLATE PER ASTM B488-01, TYPE II, 30 μ in MIN, GRADE C OVER 100 TO 200 μ in COPPER STRIKE PER MIL-C-14550.

UNLESS OTHERWISE SPECIFIED DIMENSIONS ARE IN INCHES TOLERANCES ON	DWN:	DATE	 Property of Radiall This document cannot be reproduced or communicated to a third party without prior written permission of RADIALL.		
	N.D.	08/28/15			
DECIMAL	ANGLE	CHKD:	DATE	SMA STRAIGHT JACK BULKHEAD REAR MOUNT FOR RG-180 & SIMILAR CABLES	
		D.N.	08/28/15		
		APVD:	DATE		
		J.M.	08/28/15	SIZE: A FSCM NO.: 19505 DWG NO.: 9030-1033-004 REV: A	
REFERENCE:	MATERIALS & FINISHES:	SEE NOTES			
ORIGINATED: N.D. DATE: 08/28/15	SCALE: 5:1			THIRD ANGLE PROJECTION 	SHEET 1 OF 1

9030-1033-004