

- 1.0 PERFORMANCE:  
 1.1 FREQUENCY RANGE DC-27 GHz  
 1.2 VSWR TYP < 1.25 THRU 20 GHz  
     < 1.07 (DC-11 GHz)  
     < 0.85+.02F (11-20 GHz)  
 1.3 SYSTEM IMPEDANCE 50 OHMS  
 1.4 DWV: 1000 Vrms @ 60 Hz (SEA LEVEL)  
 1.5 VOLTAGE RATING: 500 Vrms (SEA LEVEL)  
 1.6 TEMP RANGE: -65 / +165 °C

- 2.0 MATERIALS  
 2.1 SOCKET CONTACT: BeCu  
 2.2 BODY: STAINLESS STEEL 303  
 2.3 INSULATOR: PTFE  
 2.4 EMI GASKET: SILVER FILLED FLUOROSILICONE  
 (REF: MIL-DTL-83528C)  
 3.0 FINISHES  
 3.1 CONTACTS: MINIMUM PLATE OF .000050 GOLD  
     OVER .000080 NICKEL  
 3.2 BODY: PASSIVATED

- 4.0 MECHANICAL  
 4.1 INTERFACES PER MIL-STD-348  
 4.2 SOCKET MATING CHARACTERISTICS:  
     INSERTION FORCE:  $\phi.021$ , 20 OZ TYP, 30 OZ MAX  
     WITHDRAWAL FORCE:  $\phi.019$ , 0.5 OZ MIN  
 4.3 CONTACT RETENTION: 4 LBS MIN  
 4.4 DURABILITY: 500 CYCLES

DO NOT SCALE DRAWING

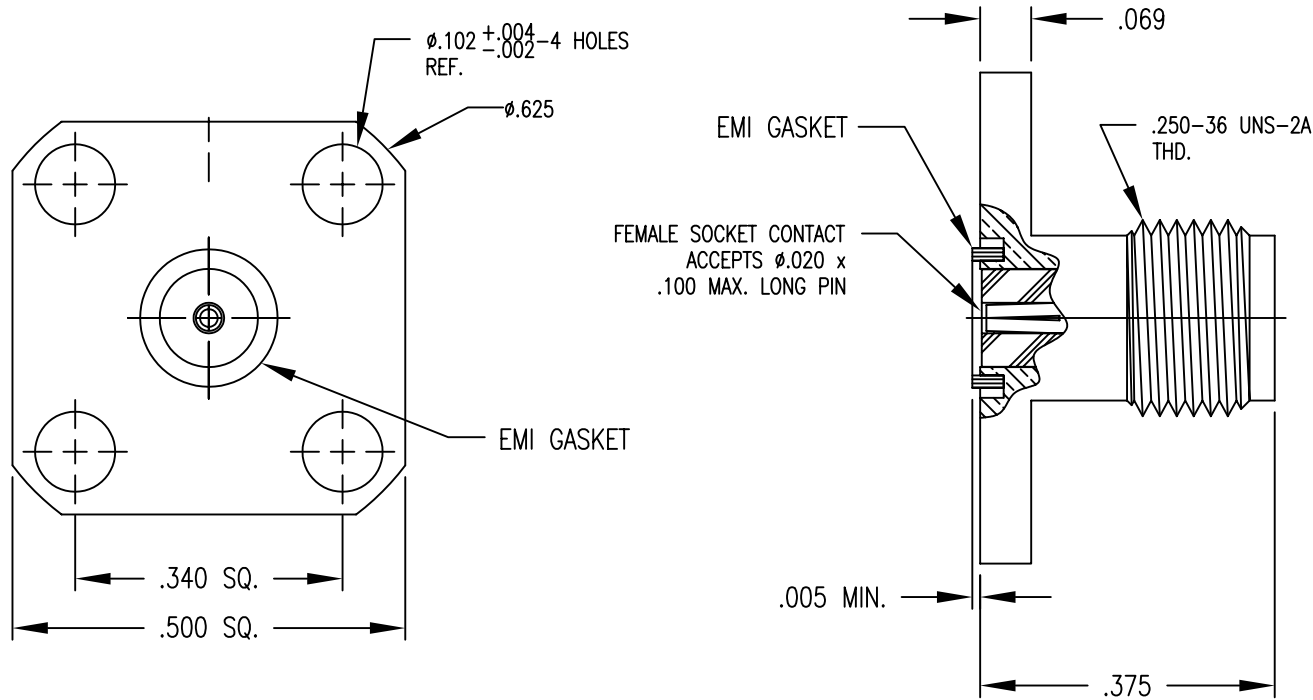

P/N 1206-58-PJ

Rev.	Revisions		Disp.	Date	Dwn.	Appd.
B	UPDATE PERFORMANCE PER TEST RESULTS		NSW	9/8/05	WJ	FSH
A	ORIGINAL		NEW	7/28/04		
RECOM.	STOCK SIZE	FT/M PCS	Ref.:	REMOVE ALL BURRS AND SHARP EDGES .005 MAX.	INTERPRET PER ASME Y14.5M-1994	

THIS DRAWING CONTAINS CONFIDENTIAL INFORMATION PROPRIETARY TO SAN-TRON INC. IT MUST NOT BE REPRODUCED OR DISCLOSED TO OTHERS OR USED IN ANY OTHER WAY, IN WHOLE OR PART EXCEPT AS AUTHORIZED IN WRITING BY SAN-TRON INCORPORATED.

UNLESS OTHERWISE SPECIFIED:  
 ALL DIMENSIONS ARE IN INCHES.  
 ALL DIMENSIONS ARE AFTER PLATING.  
 .XXX=  $\pm.005$  ALL MACHINED SURFACES  $\sqrt[63]{}$  MAX.  
 .XX=  $\pm.01$  ANG.  $\pm 1/2^\circ$  FRACTIONAL=  $\pm 1/64$   
 [◎].004 MAX. TIR. [⊥] AXIS .001

THIRD ANGLE PROJECTION

DWN	LAP	7/28/04
CHKD	SJS	
APPR	FSH	7/28/04

**SAN-TRON, INC.**  
 4 NEWBURYPORT TPK. IPSWICH MA USA 01938  
 TEL: 978 - 356 -1585 FAX: 978 - 356 -1573  
 WWW. santron.com E MAIL: santron@santron.com

TITLE SMA RECEPTACLE, STRAIGHT FEMALE, 4 HOLE FLANGE, FIELD REPLACEABLE  $\phi.020$  PIN

MATERIAL: SEE NOTE 2.0 FINISH: SEE NOTE 3.0

CAGE CODE: 50896 DWG NO. OL-1206-58-1 REV. B

SCALE X:X