

***** THIS DRAWING AND ITS CONTENTS ARE THE SOLE PROPERTY OF PRECISION CONNECTOR INC. AND ARE SUBJECT TO CHANGE WITHOUT NOTICE UNLESS OTHERWISE SPECIFIED *****

| REV. | DESCRIPTION | DATE | BY | APPVD |
|------|--------------------------|----------|-----|-------|
| A | INITIAL RELEASE | 03/20/14 | MJK | MJK |
| B | REVISED NOTES - SEE OBS. | 10/05/15 | MJK | MJK |

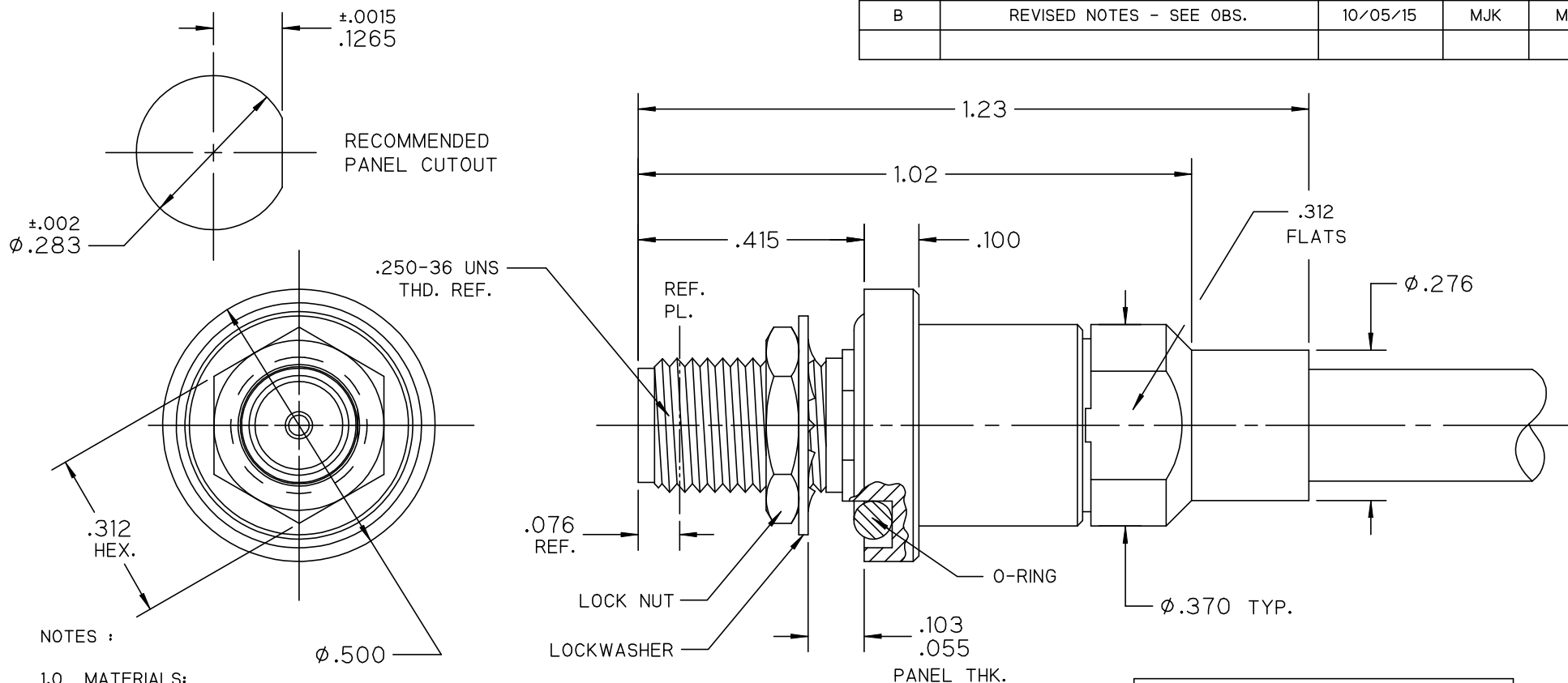

NOTES :

1.0 MATERIALS:

- 1.1 BODY, CLAMP NUT & LOCK NUT: STEEL, CORROSION RESISTANT PER ASTM-A582, UNS NO. S30300.
- 1.2 CENTER COND.: BERYLLIUM COPPER PER ASTM-B196, UNS C17300.
- 1.3 SOLDER FERRULE: BRASS PER ASTM-B16, UNS C36000.
- 1.4 LOCKWASHER: STEEL, CORROSION RESISTANT PER ASTM-A313, UNS NO. S30200.
- 1.5 O-RING: SILICONE RUBBER PER A-A-59588.
- 1.6 INSULATOR: PTFE FLUOROCARBON PER ASTM-D1710.
- 1.7 DIELECTRIC STOP: POLYETHERIMIDE THERMOPLASTIC (ULTEM 1000) PER ASTM-D5205.

2.0 FINISHES:

- 2.1 BODY, CLAMP NUT, LOCK NUT & LOCKWASHER: PASSIVATE PER SAE-AMS-2700.
- 2.2 CENTER CONTACT & SOLDER FERRULE: GOLD PLATE PER ASTM-B488, 50 MICROINCHES MIN. THK. OVER ELECTROLYTIC NICKEL PLATE PER ASTM-B689 50 MICROINCHES MIN. THK.
- 2.3 O-RING & DIELECTRICS: NONE.

3.0 SMA JACK INTERFACE PER MIL-STD-348, FIGURE 310-2.



| | | | | | |
|---------------------------------------|----------------|---|--------|-----------|----------------|
| TOLERANCES UNLESS OTHERWISE SPECIFIED | DRAWN BY: MJK | TITLE : SMA BULKHEAD JACK, SOLDER CLAMP FOR SEMFLEX HP190 CABLE | | | |
| | DATE: 03/20/14 | CAGE CODE | SCALE | SHEET NO. | DRAWING NUMBER |
| .XX ± .02 | 4MJR5 | 4:1 | 1 OF 1 | 3298-0L | REV |
| .XXX ± .005 | | | | | B |
| .XXXX ± .0005 | | | | | |
| ANGLES ± 2° | | | | | |