

PART NUMBER	ITEM ① BODY	ITEM ② CONTACT	ITEM ③ INSULATOR	ITEM ④ WASHER	ITEM ⑤ NUT
142-D7D1-B71	BRASS GOLD PL .00001 MIN OVER NICKEL PL .00005 MIN OVER COPPER PL .00005 MIN	BERYLLIUM COPPER GOLD PL .00005 MIN OVER NICKEL PL .00005 MIN OVER COPPER PL .00005 MIN	TEFLON	BRASS GOLD PL .00001 MIN OVER NICKEL PL .00005 MIN OVER COPPER PL .00005 MIN	BRASS GOLD PL .00001 MIN OVER NICKEL PL .00005 MIN OVER COPPER PL .00005 MIN
142-D7D1-B76	BRASS NICKEL PL .0001 MIN OVER COPPER PL .00005 MIN	BERYLLIUM COPPER GOLD PL .00003 MIN OVER NICKEL PL .00005 MIN OVER COPPER PL .00005 MIN	TEFLON	BRASS NICKEL PL .0001 MIN OVER COPPER PL .00005 MIN OVER	BRASS NICKEL PL .0001 MIN OVER COPPER PL .00005 MIN OVER

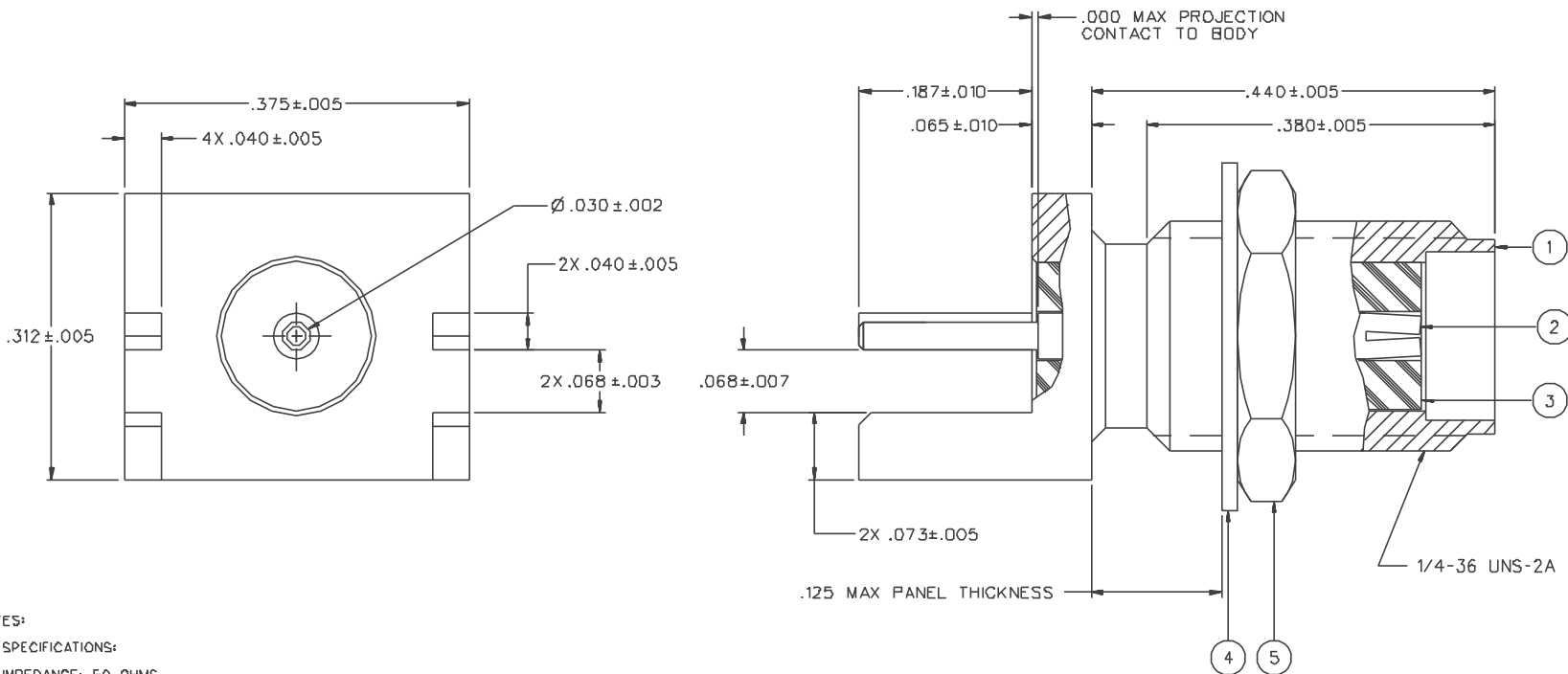

NOTES:

1. SPECIFICATIONS:

IMPEDANCE: 50 OHMS
 FREQUENCY RANGE: 0-18 GHz
 VSWR: NOT APPLICABLE
 WORKING VOLTAGE: 335 VRMS MAX AT SEA LEVEL
 DIELECTRIC WITHSTANDING VOLTAGE: 1000 VRMS MIN AT SEA LEVEL
 INSULATION RESISTANCE: 5000 MEGOHM MIN
 CONTACT RESISTANCE:
 CENTER CONTACT - INITIAL 3.0 MILLIOHM MAX, AFTER ENVIRONMENTAL 4.0 MILLIOHM MAX
 OUTER CONDUCTOR - INITIAL 2.0 MILLIOHM MAX, AFTER ENVIRONMENTAL NOT APPLICABLE
 BRAID TO BODY - NOT APPLICABLE
 CORONA LEVEL: 250 VOLTS MIN AT 70,000 FEET
 INSERTION LOSS: NOT APPLICABLE
 RF LEAKAGE: NOT APPLICABLE
 RF HIGH POTENTIAL WITHSTANDING VOLTAGE: 670 VRMS MIN AT 4 AND 7 MHz

MECHANICAL:

ENGAGE/DISENGAGE TORQUE: 2 INCH-POUNDS MAX
 MATING TORQUE: 7-10 INCH POUNDS
 COUPLING PROOF TORQUE: NOT APPLICABLE
 COUPLING NUT RETENTION: NOT APPLICABLE
 CONTACT RETENTION: 6 LBS MIN AXIAL FORCE
 4 IN-OZ MIN RADIAL TORQUE
 CABLE ACCEPTABILITY: NOT APPLICABLE
 CABLE HEX CRIMP SIZE: NOT APPLICABLE
 CABLE RETENTION: NOT APPLICABLE
 DURABILITY: 500 CYCLES MIN

ENVIRONMENTAL:

(MEETS OR EXCEEDS THE APPLICABLE PARAGRAPH OF MIL-C-39012)
 THERMAL SHOCK: MIL-STD-202, METHOD 107, CONDITION B
 OPERATING TEMPERATURE: -65 DEG C TO 165 DEG C
 CORROSION: MIL-STD-202, METHOD 101, CONDITION B
 SHOCK: MIL-STD-202, METHOD 213, CONDITION 1
 VIBRATION: MIL-STD-202, METHOD 204, CONDITION D
 MOISTURE RESISTANCE: MIL-STD-202, METHOD 106

DRAWING NO. C - 142-0701-871/880			
0 REVISIONS			
ENGINEERING RELEASE			
1	10-7-93	R H	10-12-93 ECO 42287
CHANGED: .380--.005 WAS .335--.005			
2	11-23-93	R H	12-1-93 ECO 42181
ADDED: PART NO'S 142-0701-871 AND -876, NOTES 2 AND 3			
CHANGED: .068--.007 WAS .068--.006, UPDATED GRAPHICS			
2a	2-25-94	R H	3-2-94 ECO 42292
ADDED: WASHER AND NUT TO -871, -875 AND -876, 142-0701-872			
3	3-29-94	R H	3-30-94 ECN 42380
DELETED: -B75, NOTE 3 TIN/ DIP LEGS			
* REVISION NUMBER FOLLOWED BY AN ALPHA *			
* CHARACTER INDICATES DRAWING CLARIF. *			
* CATION OR PART NUMBER ADDITION ONLY. *			
3a	6-13-94	R H	6-21-94 ECN 42520
ADDED: .000 MAX PROJECTION, CUT AWAY FLANGE DETAIL, MAX PANEL THICKNESS			
CHANGED: 4 X .040--.005 WAS 2 X .040--.005			
DELETED: .025--.010, NOTE 2, P/N 142-0701-B71/880			
4	10-24-96	R H	ECN 44266
VERSION UPDATE			
5	3-1-99	R H	ECN 46209

CUSTOMER DRAWING

THIS DRAWING TO BE INTERPRETED PER ANS Y 14.5M - 1982

"μSTATION"

COMPANY CONFIDENTIAL

TOLERANCE UNLESS OTHERWISE SPECIFIED	DRAWN BY RJB	DATE 9-27-93	 299 Johnson Ave. P.O. Box 1732 Waseca, MN 56093-0832	
DECIMALS .XX	CHECKED BY	DATE	TITLE JACK ASSEMBLY END LAUNCH SMA	
.XXX	APPROVED BY RJB	DATE 10-7-93	CODE NO.	DRAWING NO. C - 142-0701-871/880
MATL	APPROVED BY	DATE	SCALE 10:1	U/W INCH SHEET 2 OF 2
FINISH	RELEASE DATE	10-12-93		