

PART NUMBER	ITEM ① BCDY	ITEM ② CONTACT	ITEM ③ INSULATOR	ITEM ④ SEAL RING	ITEM ⑤ FLAT WASHER	ITEM ⑥ NUT
142-0593-401	BRASS GOLD PL .00001 MIN OVER NICKEL PL .00005 MIN OVER COPPER PL .00005 MIN	BERYLLIUM COPPER GOLD PL .00003 MIN OVER NICKEL PL .00005 MIN OVER COPPER PL .00005 MIN	TEFLON	SILICONE RUBBER	BRASS GOLD PL .00001 MIN OVER NICKEL PL .00005 MIN OVER COPPER PL .00005 MIN	BRASS GOLD PL .00001 MIN OVER NICKEL PL .00005 MN OVER COPPER PL .00005 MIN
142-0593-406	BRASS NICKEL PL .0001 MIN OVER COPPER PL .00005 MIN	BERYLLIUM COPPER GOLD PL .00003 MIN OVER NICKEL PL .00005 MIN OVER COPPER PL .00005 MIN	TEFLON	SILICONE RUBBER	BRASS NICKEL PL .0001 MIN OVER COPPER PL .00005 MIN	BRASS NICKEL PL .0001 MIN OVER COPPER PL .00005 MIN

DRAWING NO. C - 142-0593-401/410			
0 REVISIONS			
ENGINEERING RELEASE			
01	01-29-90	E J R A W	02-05-90 ECO 24293
ADDED: 115° C HIGH TEMP TO THERMAL SHOCK SPEC.			
02	02-27-90	E J R A W	3-8-90 ECO 24404
CHANGED: SILICONE RUBBER WAS BUNA N, HEX .500 REF WAS HEX .500+.010, .415+.005 WAS .415+- .010, DIA .241-.003 WAS DIA .241- .000+.005, DIA .258-.003 WAS DIA .258-.000+.005, 10GHz WAS 9 - 12.4 GHz, .070 WAS .085 DELETED: .615+.010, .539+.010 ADDED: .200+.010, .045-.103 PANEL THICKNESS, .032 REF, .312 HEX X .062 THK REF, 1/4 - 36 UNS - 2A			
03	11-8-90	R H B	11-9-90 ECO 24970
VERSION UPDATE			
04	9-9-91	D B	ECO 40500

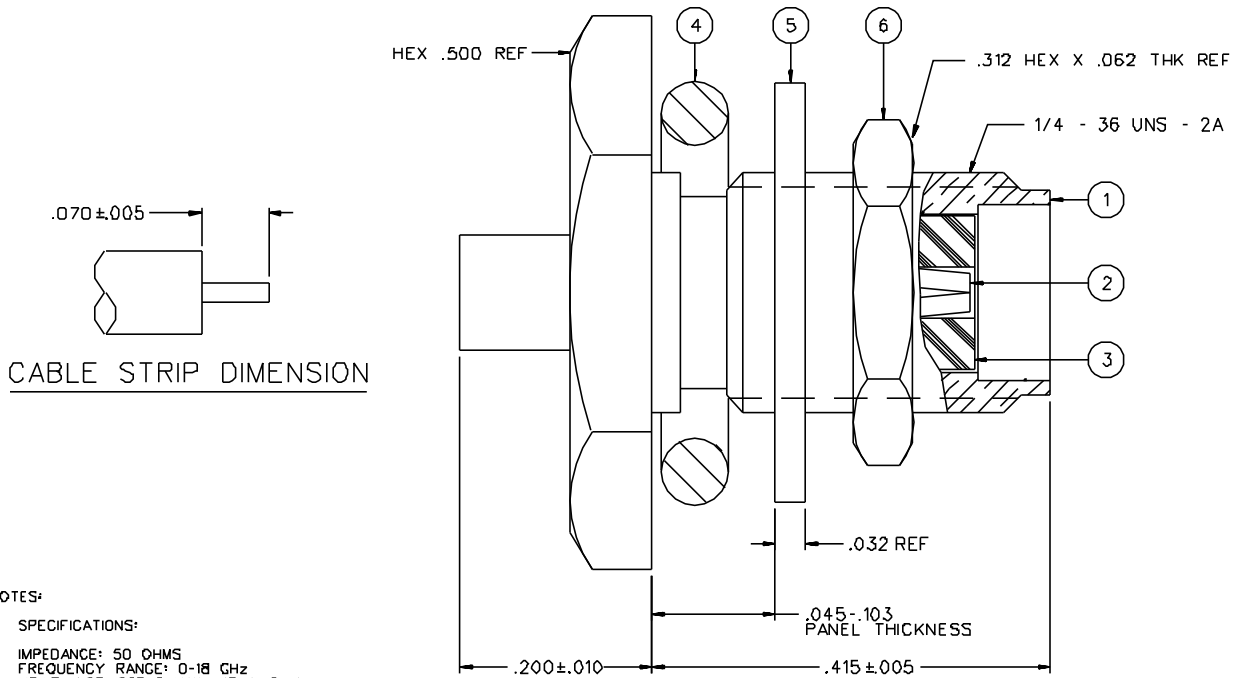

CABLE STRIP DIMENSION

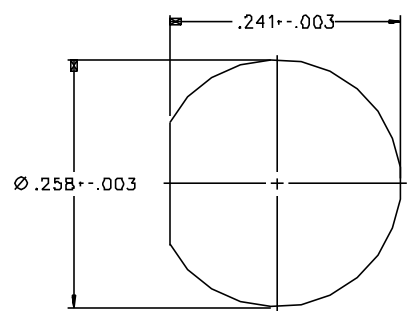

MOUNTING HOLE

NOTES:

1. SPECIFICATIONS:

IMPEDANCE: 50 OHMS
 FREQUENCY RANGE: 0-18 GHz
 VSWR: 1.07+.008 F MAX 4F IN GHz
 WORKING VOLTAGE: 335 VRMS MAX AT SEA LEVEL
 DIELECTRIC WITHSTANDING VOLTAGE: 1000 VRMS MIN AT SEA LEVEL
 INSULATION RESISTANCE: 5000 MEGOHM MIN
 CONTACT RESISTANCE:
 CENTER CONTACT - INITIAL 3.0 MILLIOHM MAX, AFTER ENVIRONMENTAL 4.0 MILLIOHM MAX
 OUTER CONDUCTOR - INITIAL 2.0 MILLIOHM MAX AFTER ENVIRONMENTAL NOT APPLICABLE
 BODY TO CABLE - 0.5 MILLIOHM MAX
 CORONA LEVEL: 250 VOLTS MIN AT 70,000 FEET
 INSERTION LOSS: .03V/F (F IN GHz) AT 10 GHz
 RF LEAKAGE: -90 DB MIN AT 2 TO 3 GHz
 RF HIGH POTENTIAL WITHSTANDING VOLTAGE: 670 VRMS MIN AT 5 TO 7.5 MHz

MECHANICAL:

ENGAGE/DISENGAGE TORQUE: 2 INCH-POUNDS MAX
 MATING TORQUE: 7-10 INCH POUNDS
 COUPLING PROOF TORQUE: NOT APPLICABLE
 COUPLING NUT RETENTION: NOT APPLICABLE
 CONTACT RETENTION: NOT APPLICABLE
 CABLE ACCEPTABILITY: RC 405 DIA .086 SEMIRIGID
 CABLE HEX CRIMP SIZE: NOT APPLICABLE
 CABLE RETENTION: 30 LBS MIN AXIAL FORCE
 16 INCH-OUNCE MIN TORQUE
 DURABILITY: 500 CYCLES MIN

ENVIRONMENTAL:

(MEETS OR EXCEEDS THE APPLICABLE PARAGRAPH OF MIL-C-39012)
 THERMAL SHOCK: MIL-STD-202, METHOD 107, CONDITION B, EXCEPT 115 DEG C HIGH TEMP
 OPERATING TEMPERATURE: -65 DEG C TO 165 DEG C
 CORROSION: MIL-STD-202, METHOD 101, CONDITION B
 SHOCK: MIL-STD-202, METHOD 213, CONDITION I
 VIBRATION: ML-STD-202, METHOD 204, CONDITION D
 MOISTURE RESISTANCE: MIL-STD-202, METHOD 106

CUSTOMER DRAWING

THIS DRAWING TO BE INTERPRETED
 PER ANSI Y 14.5M - 1982

"µSTATION"

COMPANY CONFIDENTIAL

TOLERANCE UNLESS OTHERWISE SPECIFIED	DRAWN BY EJ	DATE 9-13-89	299 Johnson Ave. P.O. Box 1732 Waseca, MN 56093-0832	
DECIMALS .XX	CHECKED BY	DATE	TITLE JACK ASSEMBLY STRAIGHT CABLED BULKHEAD SMA, RC 405	
XXX	APPROVED BY GLD	DATE 1-30-90	CODE NO.	DRAWING NO. C - 142-0593-401/410
MATL	APPROVED BY RJB	DATE 1-30-90	SCALE 10:1	U/W INCH SHEET 2 OF 2
FINISH	RELEASE DATE	DATE 2-5-90		