

REVISIONS			
REV	DESCRIPTION	DATE	APPROVED
A	INITIAL RELEASE	10/15/09	A.D.M.

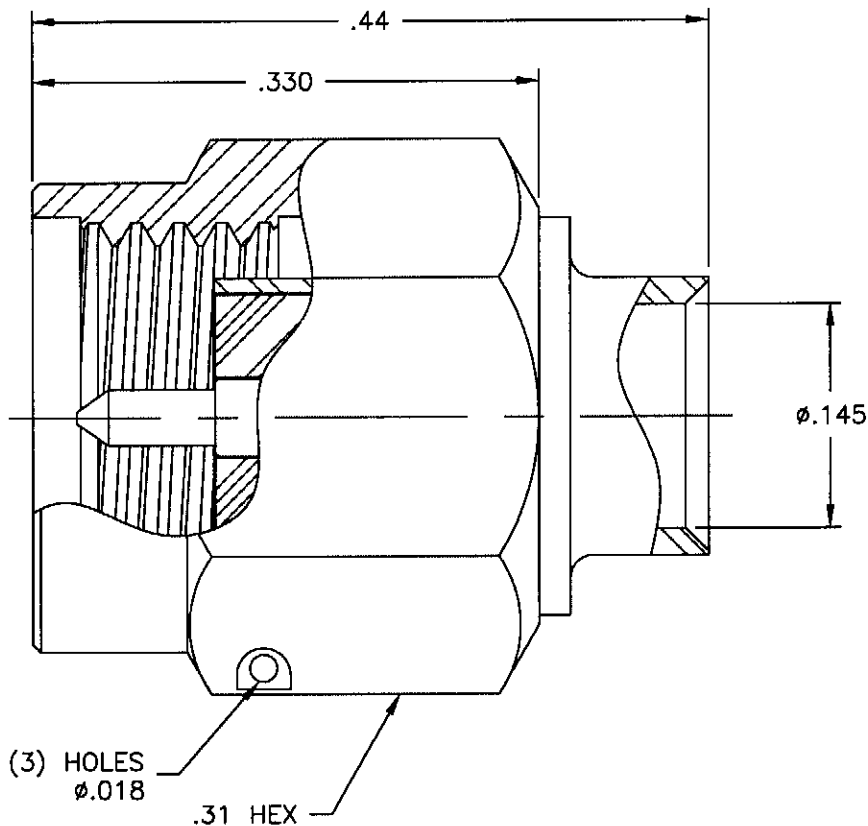

NOTES:

MATERIALS:

1. BODY & COUPLING NUT = STAINLESS STEEL PER ASTM A582, ALLOY 303, CONDITION "A".
2. INSULATOR = VIRGIN WHITE TEFLON PER ASTM D1710, GRADE 1, TYPE I, CLASS "B".
3. CONTACT & RETAINING RING = BERYLLIUM COPPER PER ASTM B196, ALLOY C17300, TEMPER TD04.
4. GASKET = SILICONE RUBBER PER ZZ-R-765, CLASS 2B, GRADE 65-75.

FINISHES:

1. BODY & COUPLING NUT = GOLD PLATE PER MIL-G-45204, TYPE II, CLASS 0, GRADE C, OVER .000050 TO .00010 STRESS FREE NICKEL PER QQ-N-290.
2. CONTACT = GOLD PLATE PER MIL-G-45204, TYPE II, CLASS 1, GRADE C, OVER .00010 TO .00020 STRESS FREE SULFAMATE NICKEL PER QQ-N-290.

Property of Radiall Incorporated
 This document cannot be reproduced or
 communicated to a third party without prior
 written permission of RADIALL Incorporated.

UNLESS OTHERWISE SPECIFIED DIMENSIONS ARE IN INCHES TOLERANCES ON		DWN: A.D.M.	DATE 10/15/09	 APPLIED ENGINEERING PRODUCTS 104 John W. Murphy Dr. New Haven, CT 06513 a RADIALL company
DECIMAL	ANGLE	CHKD: D.N.	DATE 10/15/09	
		APVD: J.M.	DATE 10/15/09	
REFERENCE:		MATERIALS & FINISHES: SEE NOTES		SMA STRAIGHT PLUG SEPARATE CONTACT DIRECT SOLDER TYPE FOR .141 S/R & SIMILAR CABLES
ORIGINATOR: A.D.M. DATE: 10/15/09		SIZE A	FSCM NO. 19505	DWG NO. 9401-1003-509
		SCALE 8:1	THIRD ANGLE PROJECTION	REV A SHEET 1 OF 1

9401-1003-509