

REVISIONS			
REV.	DESCRIPTION	DATE	APPROVED
A	INITIAL RELEASE	06/04/07	A.D.M.

PROPRIETARY INFORMATION
 NOT TO BE RELEASED
 WITHOUT WRITTEN PERMISSION
 FROM AN AUTHORIZED
 REPRESENTATIVE OF
 APPLIED ENGINEERING PRODUCTS

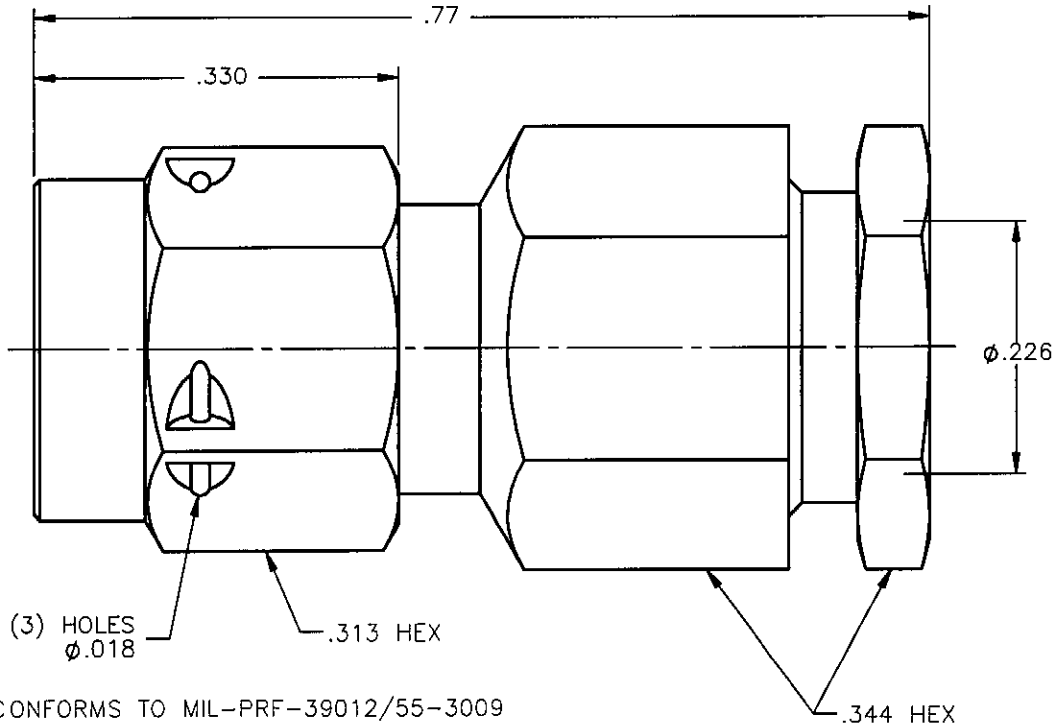

NOTES: CONFORMS TO MIL-PRF-39012/55-3009

MATERIALS:

1. BODY & COUPLING NUT = STAINLESS STEEL PER ASTM A582, ALLOY 303, CONDITION "A".
2. INSULATORS = VIRGIN WHITE TEFLON PER ASTM D1710, GRADE 1, TYPE I, CLASS "B".
3. CONTACT & RING = BERYLLIUM COPPER PER ASTM B196, ALLOY C17300, TEMPER T004.
4. FERRULE, WASHER & NUT = BRASS PER ASTM B16, ALLOY C36000, TEMPER H02.
5. GASKET = SILICONE RUBBER PER ZZ-R-765, CLASS 2B, GRADE 65-75.

FINISHES:

1. BODY & COUPLING NUT = PASSIVATE PER QQ-P-35, TYPE VI.
2. CONTACT = GOLD PLATE PER MIL-G-45204, TYPE II, CLASS 1, GRADE C, OVER .00010 TO .00020 STRESS FREE SULFAMATE NICKEL PER QQ-N-290.
3. ALL OTHER METAL PARTS = NICKEL PLATE PER QQ-N-290, CLASS 1, GRADE G, EXCEPT .0001 TO .0002 THICK OVER .00005 TO .0001 THICK COPPER PER MIL-C-14550.

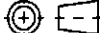
UNLESS OTHERWISE SPECIFIED DIMENSIONS ARE IN INCHES TOLERANCES ON		DWN: A.D.M.	DATE: 06/04/07	 APPLIED ENGINEERING PRODUCTS 104 John W. Murphy Dr. New Haven, CT 06513 <i>a RADIAL company</i>
		CHKD: D.N.	DATE: 06/04/07	
DECIMAL	ANGLE	APVD: J.M.	DATE: 06/04/07	SMA STRAIGHT PLUG COMPRESSION TYPE FOR RG-55 & SIMILAR CABLES
REFERENCE:	MATERIALS & FINISHES: SEE NOTES		SIZE: A FSCM NO.: 19505 DWG NO.: 9201-9553-901 REV: A	
ORIGINATED: A.D.M. DATE: 06/04/07	SCALE: 6:1		THIRD ANGLE PROJECTION  SHEET 1 OF 1	

9201-9553-901