

FILE

REVISIONS

LTR	DESCRIPTION	DATE	APPROVED
A	UPDATED TO STANDARD	7/11/97	VPS

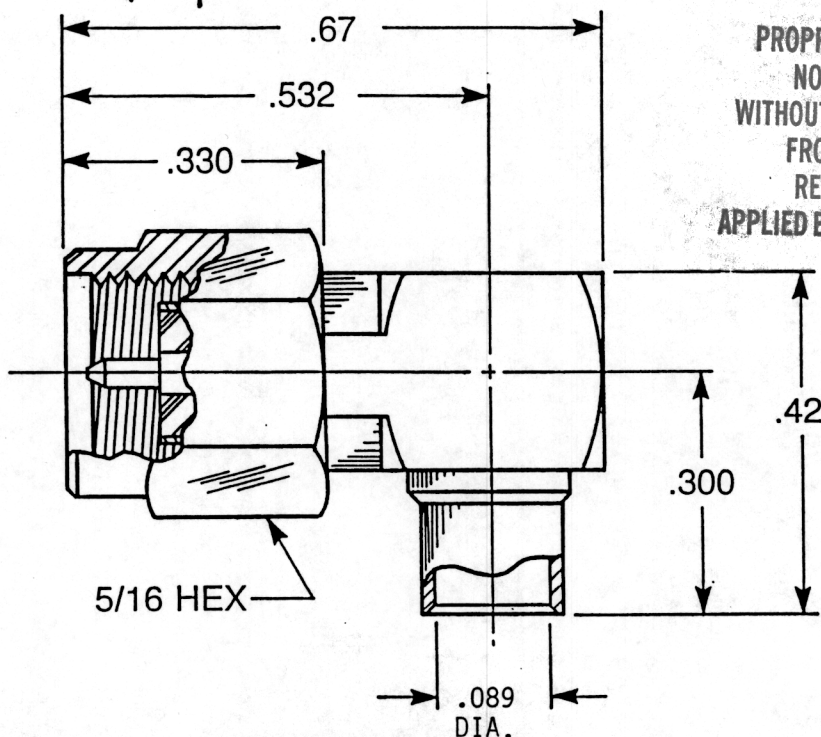

NOTES: CONFORMS TO MIL-PRF-39012

MATERIAL:

- BODIES & COUPLING NUT = STAINLESS STEEL PER ASTM A582, ALLOY 303, CONDITION "A".
- CONTACT & SNAP RING = BERYLLIUM COPPER PER ASTM B196, ALLOY C17300, TEMPER TD04.
- INSULATOR = TEFLON, VIRGIN WHITE, ASTM D1710, GRADE 1, TYPE I, CLASS "A".
- CAP = BRASS PER ASTM B16, ALLOY C36000, TEMPER H02.
- GASKET = SILICONE RUBBER PER ZZ-R-765, CLASS 2B, GRADE 65-75.

FINISHES:

- BODIES = GOLD PLATE PER MIL-G-45204, TYPE II, CLASS O, GRADE C OVER .000050 TO .00010 STRESS FREE NICKEL PER QQ-N-290.
- CONTACT = GOLD PLATE PER MIL-G-45204, TYPE II, CLASS 1, GRADE C OVER .00010 TO .00020 STRESS FREE SULFAMATE NICKEL PER QQ-N-290.
- CAP = GOLD PLATE PER MIL-G-45204 TYPE II, CLASS I, GRADE C OVER .00010 TO .00020 COPPER STRIKE PER MIL-C-14550.
- COUPLING NUT = PASSIVATE PER QQ-P-35, TYPE VI.

UNLESS OTHERWISE SPECIFIED DIMENSIONS ARE IN INCHES TOLERANCES ON FRAC. DECIMAL ANGLES 1/64 ± 2°	DRAWN VPS	DATE 7-11-97	APPLIED ENGINEERING PRODUCTS 104 John W. Murphy Drive, P.O. Box 510 New Haven, CT 06513		
	CHECKED T.D.	DATE 7-11-97	SMA RIGHT ANGLE CABLE PLUG, RG-405 CONTROL DRAWING		
MATERIAL:	APPROVED <i>[Signature]</i>	DATE 7/12/97			
	FINISH:		SCALE NTS	REV A	SHEET 1 OF 1

Design Products Co. Clearprint #1000H