

PROPRIETARY INFORMATION
 NOT TO BE RELEASED
 WITHOUT WRITTEN PERMISSION
 FROM AN AUTHORIZED
 REPRESENTATIVE OF
 APPLIED ENGINEERING PRODUCTS

REVISIONS			
REV	DESCRIPTION	DATE	APPROVED
-	INITIAL RELEASE	10/09/01	A.D.M.

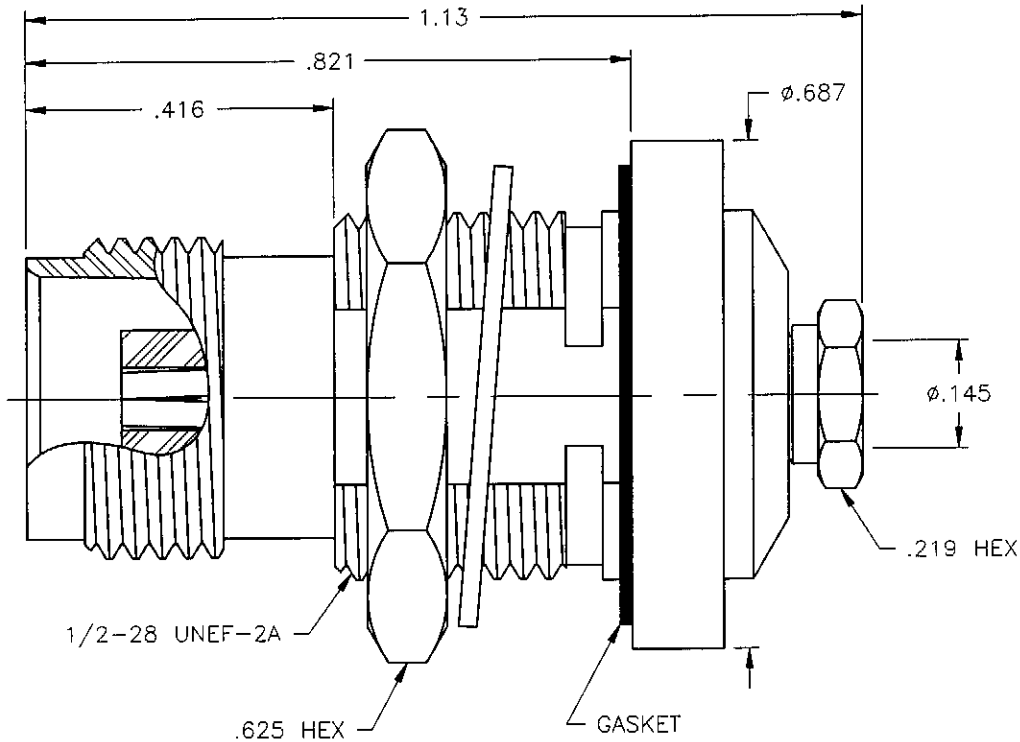

NOTES:

MATERIALS:

1. BODY = STAINLESS STEEL PER ASTM A582, ALLOY 303, CONDITION "A".
2. INSULATOR = VIRGIN WHITE TEFLON PER ASTM D1710, GRADE 1, TYPE I, CLASS "B".
3. CONTACT = BERYLLIUM COPPER PER ASTM B196, ALLOY C17300, TEMPER TD04.
4. GASKET = SILICONE RUBBER PER ZZ-R-765, CLASS 2B, GRADE 65-75.
5. LOCKWASHER = PHOSPHOR BRONZE PER ASTM B139, COPPER ALLOY C53400, TEMPER H04.
6. ALL OTHER METAL PARTS = BRASS PER ASTM B16, ALLOY C36000, TEMPER H02.

FINISHES:

1. BODY = PASSIVATE PER QQ-P-35, TYPE VI.
2. CONTACT = GOLD PLATE PER MIL-G-45204, TYPE II, CLASS 1, GRADE C, OVER .00010 TO .00020 STRESS FREE SULFAMATE NICKEL PER QQ-N-290.
3. ALL OTHER METAL PARTS = GOLD PLATE PER MIL-G-45204, TYPE II, CLASS 0, GRADE C, OVER .00010 TO .00020 COPPER STRIKE PER MIL-C-14550.

UNLESS OTHERWISE SPECIFIED DIMENSIONS ARE IN INCHES TOLERANCES ON	DWN:	DATE		APPLIED ENGINEERING PRODUCTS			
	A.D.M.	10/09/01		104 John W. Murphy Dr. New Haven, CT 06513			
DECIMAL	ANGLE	CHKD:	DATE	TNC STRAIGHT JACK BULKHEAD REAR MOUNT FOR .141 SEMI-RIGID			
		D.N.	10/09/01				
		APVD:	DATE	SIZE	FSCM NO.	DWG NO.	REV
		D.J.C.	10/09/01	A	19505	6001-2043-109	-
REFERENCE:	MATERIALS & FINISHES:		SCALE	SHEET		OF	
ORIGINATOR: A.D.M. DATE: 10/09/01	SEE NOTES		4:1	1		1	

6001-2043-109