

PAGE 1/3	ISSUE 06-12-19N	SERIES SMA	PART NUMBER R125076000
----------	-----------------	------------	------------------------

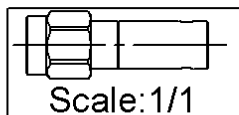

All dimensions are in mm. Tolerances according ISO 2768 m-H

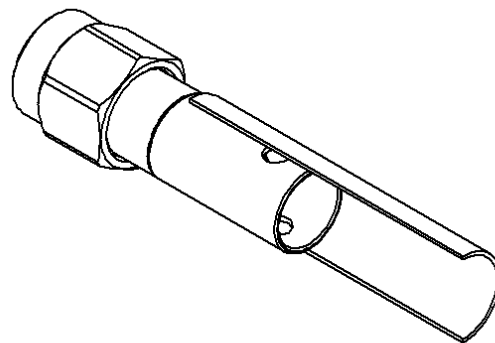
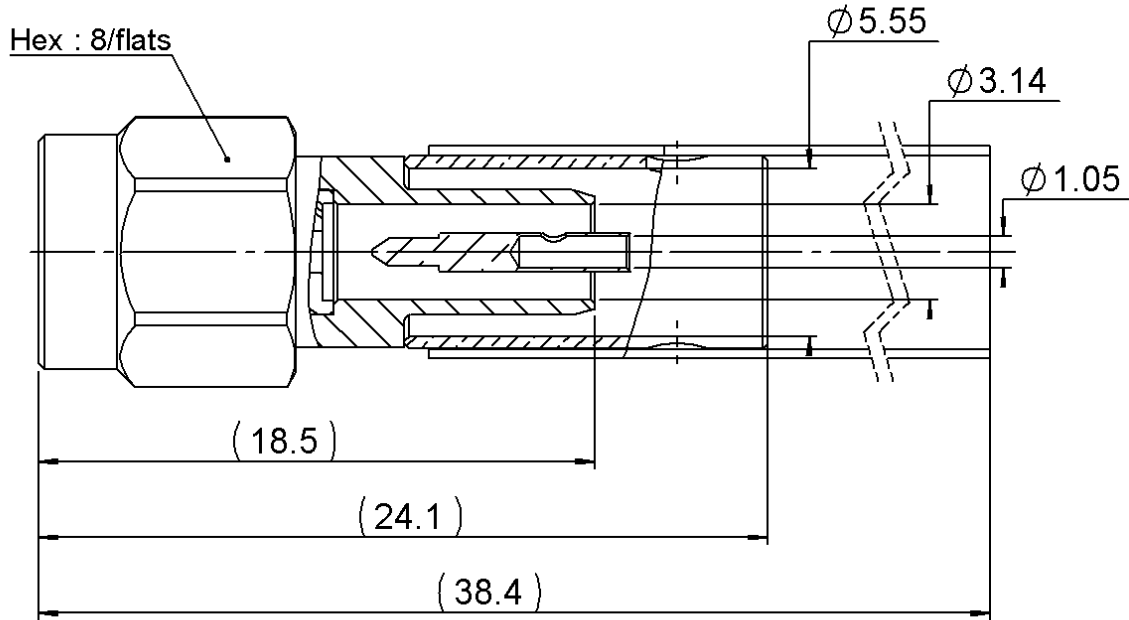
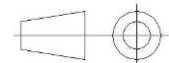

COMPONENTS	MATERIALS	PLATING (µm)
Body	STAINLESS STEEL	GOLD OVER NICKEL
Center contact	BRASS.	GOLD OVER NICKEL
Outer contact	-	-
Insulator	PTFE	
Gasket	SILICONE RUBBER	
Others parts	STAINLESS STEEL	GOLD OVER NICKEL
-	-	-
-	-	-

PAGE 2/3	ISSUE 06-12-19N	SERIES SMA	PART NUMBER R125076000
-----------------	------------------------	-------------------	-------------------------------

PACKAGING

Standard 100	Unit Contact us	Other Contact us
------------------------	---------------------------	----------------------------

ELECTRICAL CHARACTERISTICS

Impedance	50	Ω
Frequency	0-12.4	GHz
VSWR	1.15 + 0,0100	x F(GHz) Maxi
Insertion loss	0.06	√F(GHz) dB Maxi
RF leakage	- (60)	- F(GHz)) dB Maxi
Voltage rating	335	Veff Maxi
Dielectric withstanding voltage	1000	Veff mini
Insulation resistance	5000	MΩ mini

MECHANICAL CHARACTERISTICS

Center contact retention		
Axial force – Mating End	NA	N mini
Axial force – Opposite end	NA	N mini
Torque	NA	N.cm mini
Recommended torque		
Mating	100	N.cm
Panel nut	NA	N.cm
Clamp nut	NA	N.cm
A/F clamp nut	0,0000	mm
Mating life	500	Cycles mini
Nominal Weight (Add +15% for max weight)	3,8300	g

ENVIRONMENTAL

Operating temperature	-65/+165	°C
Hermetic seal	NA	Atm.cm3/s
Panel leakage	NA	

SPECIFICATION

AMD BA LEA A 00
03 COC 9 MAG-202(13/06/88)

CABLE ASSEMBLY

Stripping	a	b	c	d	e	f
mm	3,5	7	13,5	0	10	0

Assembly instruction:

Recommended cable(s)

RG 223
RG 142 BU
RG 400
KX 23
RG 142 FTX

Characteristics indicated on this data sheet are those that can be achieved with the highest performance cable. Intrinsic limitations of the cable may diminish the performance of the assembly

Cable retention

- pull off	204	N mini
- torque	NA	N.cm

TOOLING

Part Number	Description	Hexagon
R282235011	CRIMPING DIES M22520/5-11	5.40
R282293000	CRIMPING TOOL M22520/5-01	-
R282223000	CRIMPING TOOL	5.40

OTHER CHARACTERISTICS

-

PAGE 3/3	ISSUE 06-12-19N	SERIES SMA	PART NUMBER R125076000
----------	-----------------	------------	------------------------

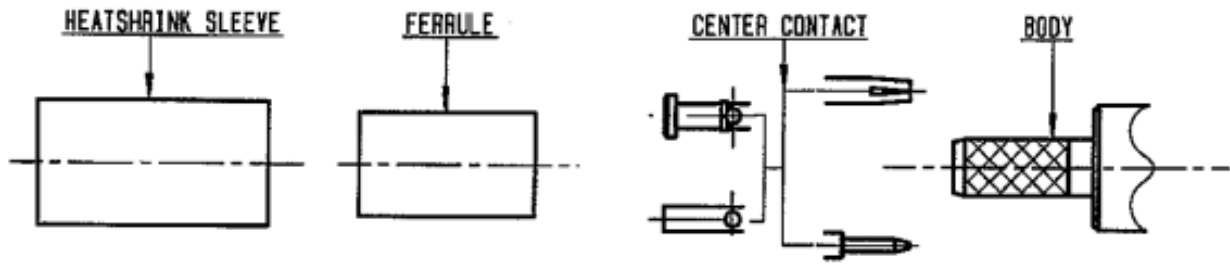

①

Slide ferrule and heatshrink sleeve onto cable .
Strip the cable .
-
-

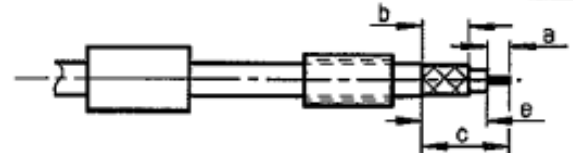

Stripping	a	b	c	d	e
inch	0.138	0.276	0.531	0	0.394
mm	3.5	7	13.5		10

②

Slide center contact on until it bottoms against cable dielectric .
Solder center contact .
Clean soldered area .
-
-

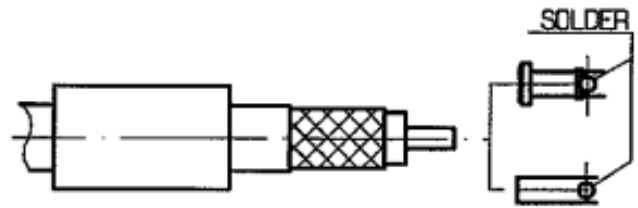

③

Fan the braid .
Slide cable into body until it bottoms against insulator .
Slide ferrule over the braid .
(In direction F)

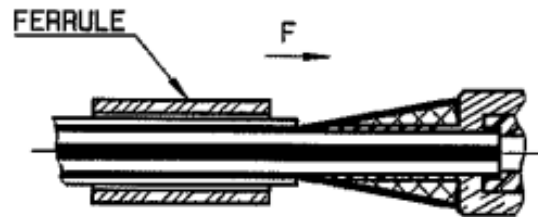

④

Crimp the ferrule with crimping tool R 282 223 000 (Hex. : 5.41) or crimping tool R 282 293 000 (M22520/5-01) + dies R 282 235 011 (M22520/5-11)
Cut the excess of braid if necessary
Slide sleeve over ferrule and heatshrink in place .
-
-

Shrink the heatshrink sleeve

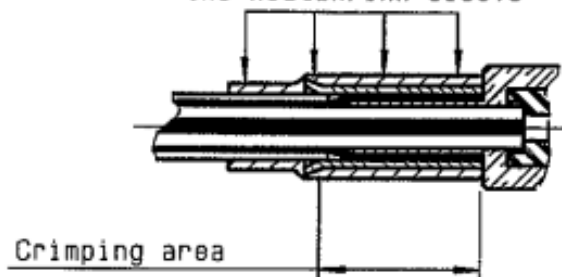

Mouser Electronics

Authorized Distributor

Click to View Pricing, Inventory, Delivery & Lifecycle Information:

Radial:

[R125076000](#) [R125076000W](#)