

REVISIONS			
REV.	DESCRIPTION	DATE	APPROVED
A	INITIAL RELEASE	07/28/11	J.S.

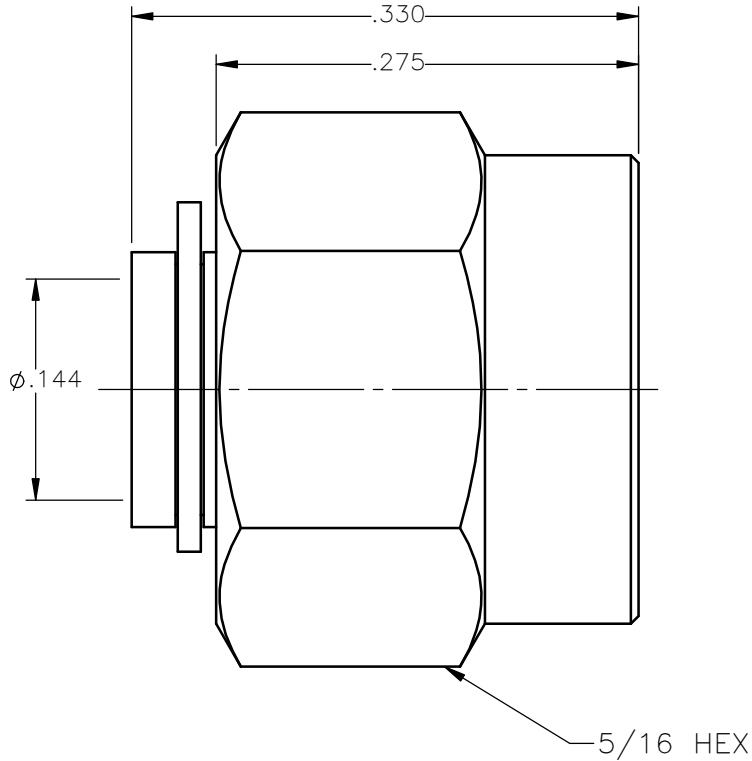



NOTES:

MATERIALS:

1. BODY = STAINLESS STEEL PER ASTM A582, ALLOY 303, CONDITION "A".
2. COUPLING NUT = STAINLESS STEEL PER ASTM A582, ALLOY 303, CONDITION "A".
3. RETAINING RING = BERYLLIUM COPPER PER ASTM B196, ALLOY C17300, TEMPER TD04.
4. GASKET = SILICONE RUBBER PER ZZ-R-765, CLASS 2B, GRADE 65-75.

FINISHES:

1. BODY = GOLD PLATE PER MIL-G-45204, TYPE II, CLASS 0, GRADE C, OVER .000050 TO .00010 STRESS FREE NICKEL PER QQ-N-290.
2. COUPLING NUT = PASSIVATE PER QQ-P-35, TYPE VI.
3. RETAINING RING = NICKEL PLATE PER QQ-N-290, CLASS 1, GRADE G, EXCEPT .0001 TO .0002 THICK OVER .00005 TO .0001 THICK COPPER PER MIL-C-14550.

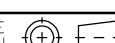
UNLESS OTHERWISE SPECIFIED DIMENSIONS ARE IN INCHES TOLERANCES ON	DWN: J.S.	DATE 07/28/11	 <b>Property of Radiall</b> This document cannot be reproduced or communicated to a third party without prior written permission of RADIALL.		
	CHKD: D.N.	DATE 07/28/11			
DECIMAL	ANGLE	APVD: J.M.	DATE 07/28/11	<b>STRAIGHT PLUG FOR .141 SEMI RIGID &amp; SIMILAR CABLES</b>	
REFERENCE:	MATERIALS & FINISHES: SEE NOTES	SIZE A	FSCM NO. 19505		DWG NO. 9631-1063-009
ORIGINATED: J.S. DATE: 07/28/11		SCALE 8:1	THIRD ANGLE PROJECTION		SHEET 1 OF 1

9631-1063-009