

NOTICE OF PROPRIETARY RIGHTS THIS DOCUMENT CONTAINS CONFIDENTIAL TECHNICAL DATA, INCLUDING TRADE SECRETS, PROPRIETARY TO TIMES MICROWAVE SYSTEMS. DISCLOSURE OF THIS DATA IS EXPRESSLY CONDITIONED UPON YOUR ASSENT THAT ITS USE IS LIMITED TO USE WITHIN YOUR COMPANY ONLY. ANY OTHER USE IS STRICTLY PROHIBITED WITHOUT THE PRIOR WRITTEN CONSENT OF TIMES MICROWAVE SYSTEMS.

SYM	REVISION DESCRIPTION	DFTM	DATE	APPD	DATE
A	RELEASED FOR PRODUCTION	N. N. N	8/21/13	J. D. B.	9/10/13

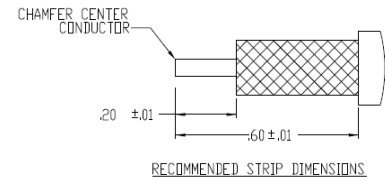
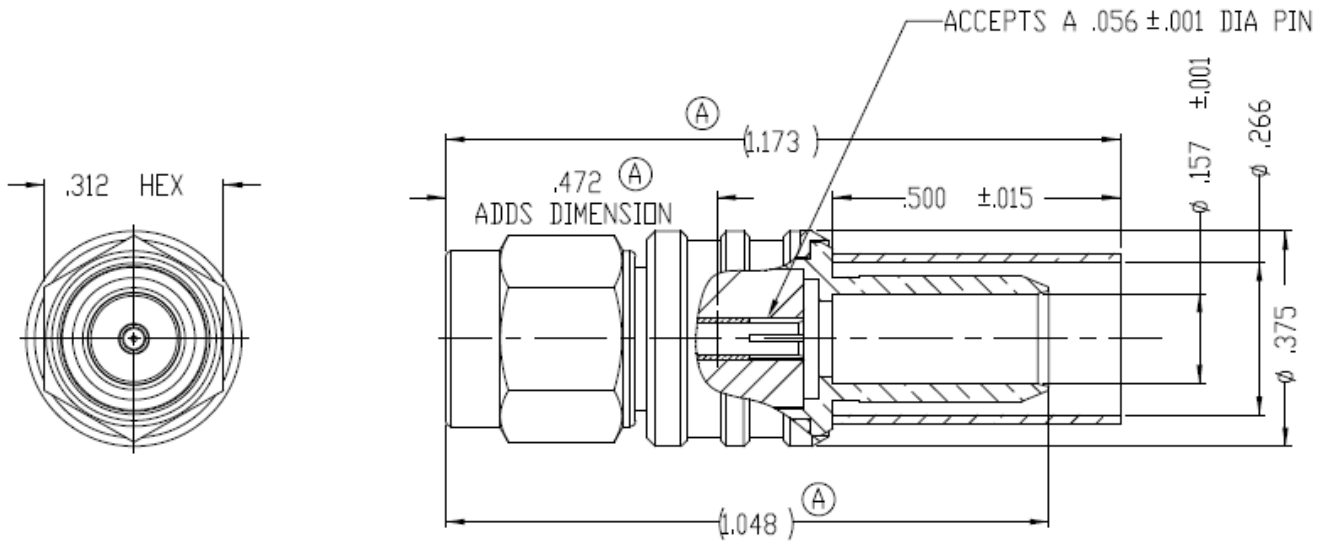

NOTES:

- ASSEMBLED CONNECTOR INTERFACE IS DESIGNED IN ACCORDANCE WITH MIL-STD-348
- MATERIAL:**
 BODY, NUT, CLAMP - BRASS PER ASTM B16, C36000 ALLOY, TEMPER H02
 INSULATOR - TEFLON PER ASTM D1710, TYPE 1, GRADE 1, CLASS A
 GASKET - SILICONE RUBBER PER A-A-59588, 50-75 DUROMETER
 SHRINK SLEEVE - HEAT SHRINKABLE ATUM PER MIL-I-23053/4 (NOT SHOWN)
 CRIMP SLEEVE - D.H.P. COPPER CDA, ALLOY #122, TEMPER HARD
 CONTACT & LOCKING RING - BERYLLIUM COPPER PER ASTM B196, C17300 ALLOY, CONDITION HT
- FINISH:**
 CONTACT - GOLD PLATE PER ASTM B488
 CRIMP SLEEVE - SULFAMATE NICKEL PER MIL-P-27418
 ALL OTHER METAL PARTS - ALBALOY PLATE PER DELTA SPEC. 111197

MATL:	UNLESS OTHERWISE SPECIFIED		DFTM. N. N. N	TIMES MICROWAVE SYSTEMS	
	ALL DIMENSIONS ARE IN INCHES MACHINED SURFACES FINISH 63 RMS MAX. REMOVE ALL BURRS .004 MAX. BREAK MACHINE CORNERS .005 MAX. FILLET R. TOLERANCES ON DECIMALS .XX ±.01 .XXX ±.005 ANGLES ± 1° FRACTIONS ± 1/64		DATE 8/21/13		
USED ON: A	DO NOT SCALE DRAWING		CHKD. J. D. B.	EZ-240-SM-X CONNECTOR ASSEMBLY SMAM for LMR-240	
			DATE 9/10/13		
SCALE: NONE	DWG. SIZE: A	CODE IDENT: 68999	APPD. J. D. B.	DATE 9/10/13	REV: A
				SHEET: 1 of 1	SD3190-2897