

***** THIS DRAWING AND ITS CONTENTS ARE THE SOLE PROPERTY OF PRECISION CONNECTOR INC. AND ARE SUBJECT TO CHANGE WITHOUT NOTICE UNLESS OTHERWISE SPECIFIED *****

REV.	DESCRIPTION	DATE	BY	APPVD
A	PRELIMINARY RELEASE	12/13/12	MJK	MJK

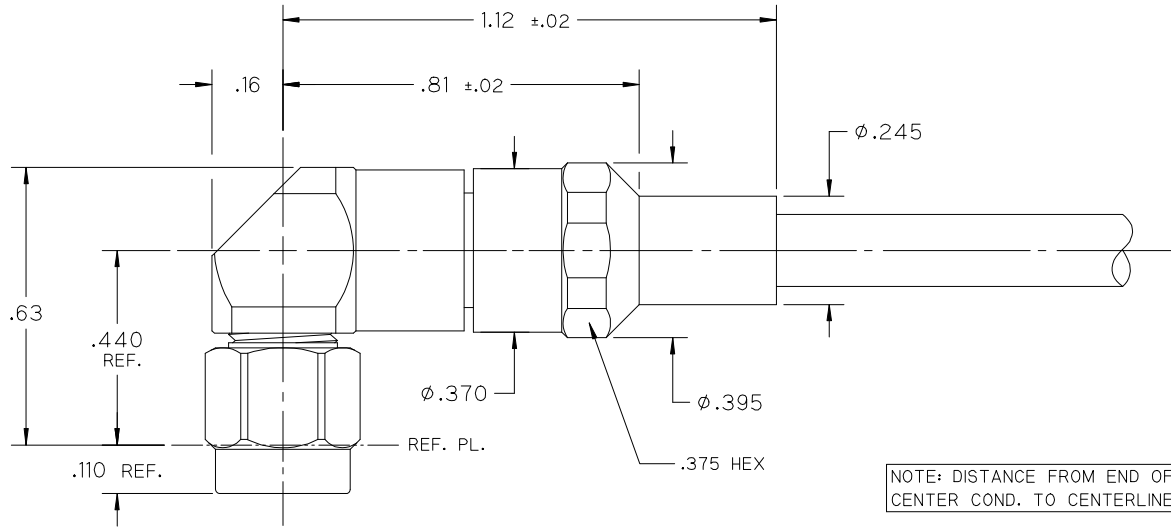

NOTES :

1.0 MATERIALS:

- 1.1 BODY, COUPLING & CLAMP NUTS: STEEL, CORROSION RESISTANT PER ASTM-A582, UNS NO. S30300.
- 1.2 CENTER CONTACT(S): BERYLLIUM COPPER PER ASTM-B196, UNS C17300.
- 1.3 SOLDER FERRULE: BRASS PER ASTM-B16, UNS C36000.
- 1.4 GASKET: SILICONE RUBBER PER A-A-59588.
- 1.5 INSULATOR(S): PTFE FLUOROCARBON PER ASTM-D1710.

2.0 FINISHES:

- 2.1 CENTER CONTACT(S) & SOLDER FERRULE: GOLD PLATE PER ASTM-B488, 50 MICROINCHES MIN. THK. OVER ELECTROLYTIC NICKEL PLATE PER ASTM-B689 50 MICROINCHES MIN. THK.
- 2.2 BODY, COUPLING & CLAMP NUTS: PASSIVATE PER SAE-AMS-2700.
- 2.3 GASKET & DIELECTRICS: NONE.
- 3.0 INTERFACE: SMA PLUG PER PCI INTERFACE SPECIFICATION PCI-SMAP. (MEETS MIL-PRF-39012, FIG. 310-1).



TOLERANCES UNLESS OTHERWISE SPECIFIED	DRAWN BY: MJK	DESC.: SMA RT. ANGLE PLUG. SOLDER CLAMP FOR HARBOUR SS402 CABLE			
	DATE: 12/13/12	CAGE CODE	SCALE	SHEET NO.	DRAWING NUMBER
.XX ± .02		4MJR5	2:1	1 OF 1	3819-0L
.XXX ± .005					
.XXXX ± .0005					
ANGLES ± 2°					REV A