

PART NUMBER	ITEM ① BODY {2 PIECE}	ITEM ② INTERFACE	ITEM ③ CONTACT	ITEM ④ INSULATOR	ITEM ⑤ CRIMP SLEEVE	ITEM ⑥ END CAP
131-3403-101	BRASS GOLD PL .00001 MIN OVER NICKEL PL .00005 MIN OVER COPPER PL .00005 MIN	BERYLLIUM COPPER GOLD PL .00003 MIN OVER NICKEL PL .00005 MIN OVER COPPER PL .00005 MIN	BERYLLIUM COPPER GOLD PL .00003 MIN OVER NICKEL PL .00005 MIN OVER COPPER PL .00005 MIN	TEFLON	COPPER GOLD PL .00001 MIN OVER NICKEL PL .00005 MIN OVER COPPER PL .00005 MIN	BRASS GOLD PL .00001 MIN OVER NICKEL PL .00005 MIN OVER COPPER PL .00005 MIN
131-3403-106	BRASS NICKEL PL .0001 MIN OVER COPPER PL .00005 MIN	BERYLLIUM COPPER GOLD PL .00003 MIN OVER NICKEL PL .00005 MIN OVER COPPER PL .00005 MIN	BERYLLIUM COPPER GOLD PL .00003 MIN OVER NICKEL PL .00005 MIN OVER COPPER PL .00005 MIN	TEFLON	COPPER NICKEL PL .0001 MIN OVER COPPER PL .00005 MIN	BRASS NICKEL PL .0001 MIN OVER COPPER PL .00005 MIN
131-3403-116	BRASS NICKEL PL .0001 MIN OVER COPPER PL .00005 MIN	BERYLLIUM COPPER NICKEL PL .0001 MIN OVER COPPER PL .00005 MIN	BERYLLIUM COPPER GOLD PL .00003 MIN OVER NICKEL PL .00005 MIN OVER COPPER PL .00005 MIN	TEFLON	COPPER NICKEL PL .0001 MIN OVER COPPER PL .00005 MIN	BRASS NICKEL PL .0001 MIN OVER COPPER PL .00005 MIN

DRAWING NO. C - 131-3403-101/120	
0 REVISIONS	
ENGINEERING RELEASE	
01 09-21-88	EJ LCSRJB 9-26-88 ECO 23551
CHANGED: .545 $\pm$ .010 WAS $\pm$ .015.	
2 8-9-90	J R A W 8-10-90 ECO 24816
ADDED: (50 OHM CABLE ONLY) TO VSWR, INSERTION LOSS AND RF LEAK SPECS. "GOLD PLATED INITIAL..." AND "NICKEL PLATED INITIAL..." TO BRAID TO BODY. CHANGED: RF LEAK 2.5 GHZ WAS 2 TO 3 GHZ, RF HIGH POT 4 AND 7 MHZ WAS 5 MHZ	
3 4-2-93	R I T R P 4-14-93 H K L B A H ECO 41752
VERSION UPDATE	
***** • REVISION NUMBER FOLLOWED BY AN ALPHA • • CHARACTER INDICATES DRAWING CLARIFICATION • • CAUTION ON PART NUMBER ADDITION ONLY. • *****	
3a 4-25-94	R I T R P 5-10-94 H K L B A H ECN 42374
ADDED: P/N 131-3403-104	
4 11-14-96	R I T R P H W A A A ECN 44281
CHANGED: .505 $\pm$ .025 WAS .534 $\pm$ .025, .380 $\pm$ .030 WAS .400 $\pm$ .030, .289 $\pm$ .015 WAS .312 $\pm$ .015, .177 $\pm$ .015 WAS .219 $\pm$ .015 DELETED: DIA .320 MAX, P/N 131-3402-104 ADDED: $\square$ .250 $\pm$ .010	
5 2-7-00	R I T R P H P L K B A ECN 46865

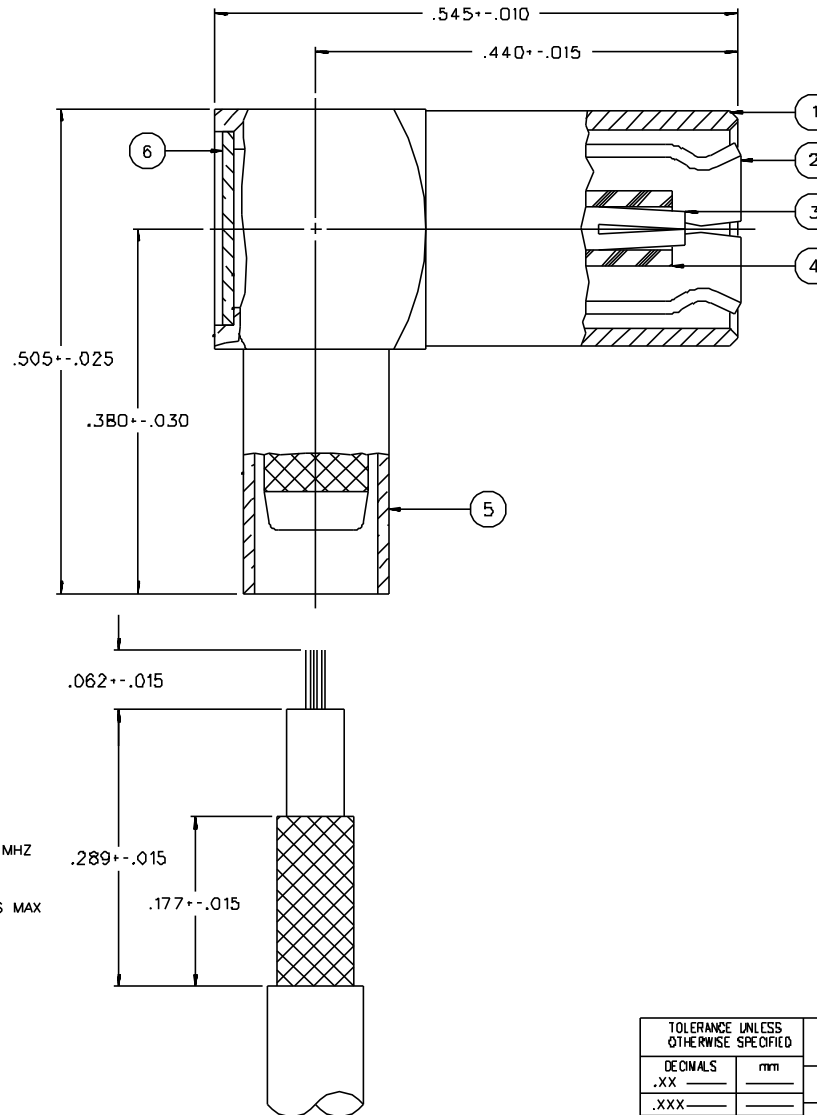
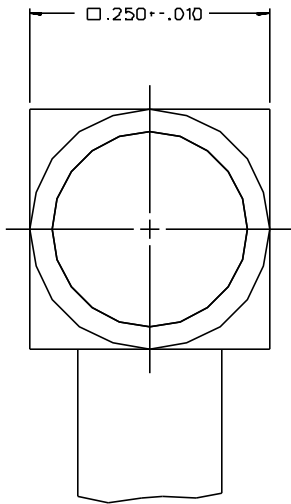

CABLE STRIP DIMENSIONS

NOTES:

1. SPECIFICATIONS:

IMPEDANCE: 50 OHMS  
 FREQUENCY RANGE: 0-4 GHZ  
 VSWR: 1.35 $\pm$ .04 F (F IN GHZ) (50 OHM CABLE ONLY)  
 WORKING VOLTAGE: 335 VRMS MAX AT SEA LEVEL  
 DIELECTRIC WITHSTANDING VOLTAGE: 1000 VRMS MIN AT SEA LEVEL  
 INSULATION RESISTANCE: 1000 MEGOHM MIN  
 CONTACT RESISTANCE:  
 CENTER CONTACT - INITIAL 12 MILLIOHM MAX, AFTER ENVIRONMENTAL 16 MILLIOHM MAX  
 OUTER CONDUCTOR - GOLD PLATED INITIAL 1 MILLIOHM MAX, AFTER ENVIRONMENTAL 1.5 MILLIOHM MAX  
 NICKEL PLATED INITIAL 2.5 MILLIOHM MAX, AFTER ENVIRONMENTAL 3.5 MILLIOHM MAX  
 BRAID TO BODY - GOLD PLATED INITIAL 1 MILLIOHM MAX, AFTER ENVIRONMENTAL NOT APPLICABLE  
 NICKEL PLATED INITIAL 2.5 MILLIOHM MAX, AFTER ENVIRONMENTAL NOT APPLICABLE  
 CORONA LEVEL: 250 VOLTS MIN AT 70,000 FEET  
 INSERTION LOSS: .60 DB MAX AT 1.5 GHZ (50 OHM CABLE ONLY)  
 RF LEAKAGE: -.55 DB MIN AT 2.5 GHZ (50 OHM CABLE ONLY)  
 RF HIGH POTENTIAL WITHSTANDING VOLTAGE: 700 VRMS MIN AT 4 AND 7 MHZ

MECHANICAL:

ENGAGE/DISENGAGE FORCE: INITIAL 14 LBS MAX, AFTER DURABILITY 14 LBS MAX  
 ENGAGEMENT/2 LBS MIN DISENGAGEMENT  
 MATING TORQUE: NOT APPLICABLE  
 COUPLING PROOF TORQUE: NOT APPLICABLE  
 COUPLING NUT RETENTION: NOT APPLICABLE  
 CONTACT RETENTION: 4 LBS MIN AXIAL FORCE  
 CABLE ACCEPTABILITY: RG 18B/U, RG 316/U, RG 174/U, RG 161/U  
 RG 179/U, RG 1B7/U  
 CABLE HEX CRIMP SIZE: .12B  
 CABLE RETENTION: 20 LBS MIN OR CABLE BREAKING STRENGTH  
 DURABILITY: 500 CYCLES MIN

ENVIRONMENTAL:

(MEETS OR EXCEEDS THE APPLICABLE PARAGRAPH OF MIL-C-39012)  
 THERMAL SHOCK: MIL-STD-202, METHOD 107, CONDITION B  
 OPERATING TEMPERATURE: -65 DEG C TO 165 DEG C  
 CORROSION: MIL-STD-202, METHOD 101, CONDITION B  
 SHOCK: MIL-STD-202, METHOD 213, CONDITION B  
 VIBRATION: MIL-STD-202, METHOD 204, CONDITION B

CUSTOMER DRAWING

THIS DRAWING TO BE ENTERPRETED PER ANSII 14.5M - 1982

"μSTATION"

COMPANY CONFIDENTIAL

TOLERANCE UNLESS OTHERWISE SPECIFIED	DRAWN BY EJ	DATE 7-27-88	Johnson Components 299 Johnson Ave. P.O. Box 1732 Waseca, MN 56093-0832	
.XX _____ mm	CHECKED BY	DATE	TITLE PLUG ASSEMBLY RA CABLED SMB, 50 OHM, RG 316	
.XXX _____	APPROVED BY LCS	DATE 9-21-88	CODE NO.	DRAWING NO. C - 131-3403-101/120
WALT _____	APPROVED BY RJB	DATE 9-21-88	SCALE 10:1	U/W INCH SHEET 2 OF 2
FINISH _____	RELEASE DATE	9-26-88		