

REVISIONS			
REV.	DESCRIPTION	DATE	APPROVED
A	INITIAL RELEASE	10/18/10	A.D.M.

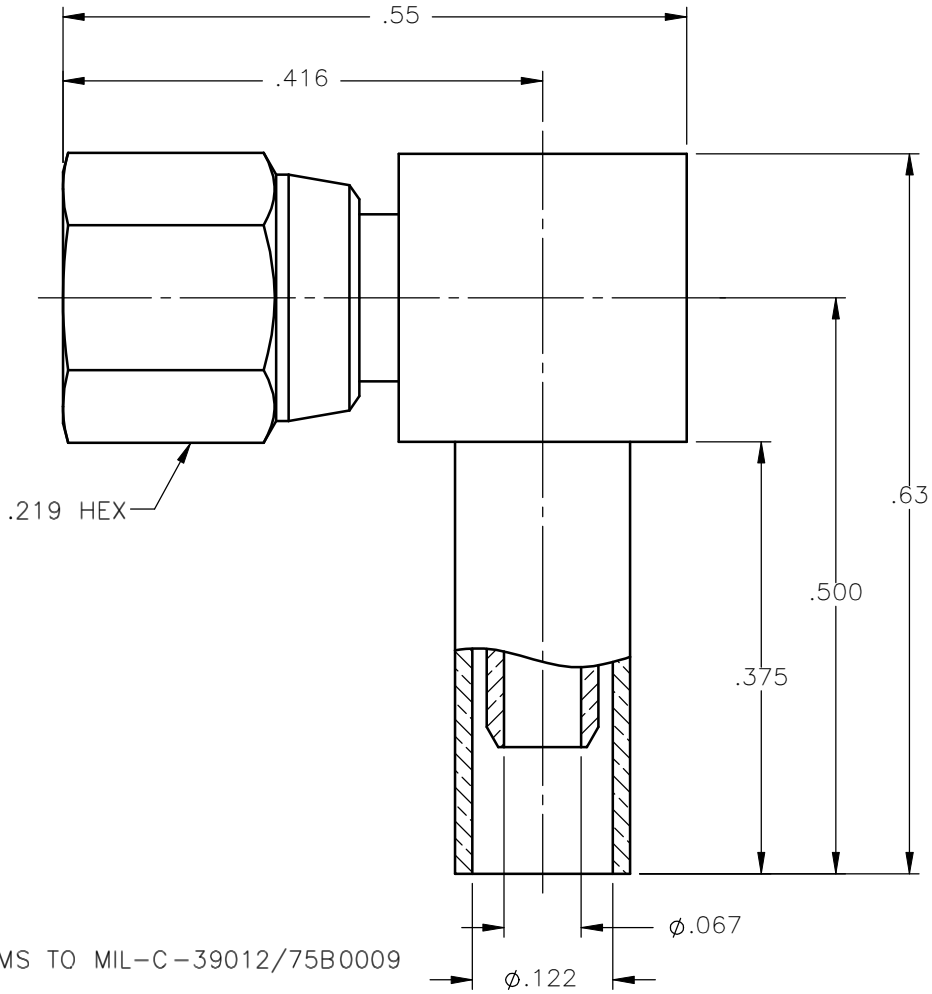

NOTES: CONFORMS TO MIL-C-39012/75B0009

MATERIALS:

1. INSULATORS = VIRGIN WHITE TEFLON PER ASTM D1710, GRADE 1, TYPE I, CLASS "B".
2. CONTACT = BERYLLIUM COPPER PER ASTM B196, ALLOY C17300, TEMPER TD04.
3. CRIMP SLEEVE = SEAMLESS LOWLEAD BRASS TUBE, ALLOY 330, SOFT ANNEAL TEMPER, .025/.060 GRAIN SIZE OR SEAMLESS COPPER TUBE PER ASTM B75, TYPE C12000, TEMPER: LIGHT ANNEAL O50 EXCEPT YIELD STRENGTH.
4. SHRINK SLEEVE (NOT SHOWN) = THERMOFIT SCL, BLACK.
5. ALL OTHER METAL PARTS = BRASS PER ASTM B16, ALLOY C36000, TEMPER H02.

FINISHES:

1. BODIES = GOLD PLATE PER MIL-G-45204, TYPE II, CLASS 1, GRADE C, OVER .00010 TO .00020 COPPER STRIKE PER MIL-C-14550.
2. CONTACT = GOLD PLATE PER MIL-G-45204, TYPE II, CLASS 1, GRADE C, OVER .00010 TO .00020 STRESS FREE SULFAMATE NICKEL PER QQ-N-290.
3. ALL OTHER METAL PARTS = GOLD PLATE PER MIL-G-45204, TYPE II, CLASS 0, GRADE C, OVER .00010 TO .00020 COPPER STRIKE PER MIL-C-14550.

UNLESS OTHERWISE SPECIFIED DIMENSIONS ARE IN INCHES TOLERANCES ON	DWN:	DATE	
	A.D.M.	10/18/10	
	CHKD:	DATE	
DECIMAL	ANGLE	M.J.	10/18/10
		APVD:	DATE
		J.M.	10/18/10
REFERENCE:	MATERIALS & FINISHES:		
ORIGINATED: A.D.M. DATE: 10/18/10	SEE NOTES		



Property of Radiall
This document cannot be reproduced or communicated to a third party without prior written permission of RADIALL.

SMC RIGHT ANGLE FEMALE PLUG
CRIMP TYPE
FOR RG-316 & SIMILAR CABLES

SIZE	FSCM NO.	DWG NO.	REV
A	19505	1105-1521-903	A
SCALE 6:1		THIRD ANGLE PROJECTION	SHEET 1 OF 1

1105-1521-903