

MALE STRAIGHT RECEPTACLE FOR PCB
PIN IN PASTE - SMOOTH BORE

R222.428.700

Series : SMP

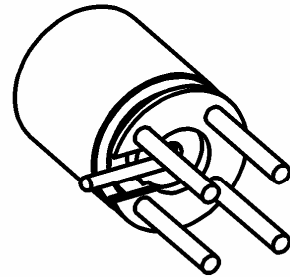
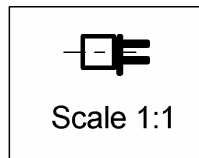
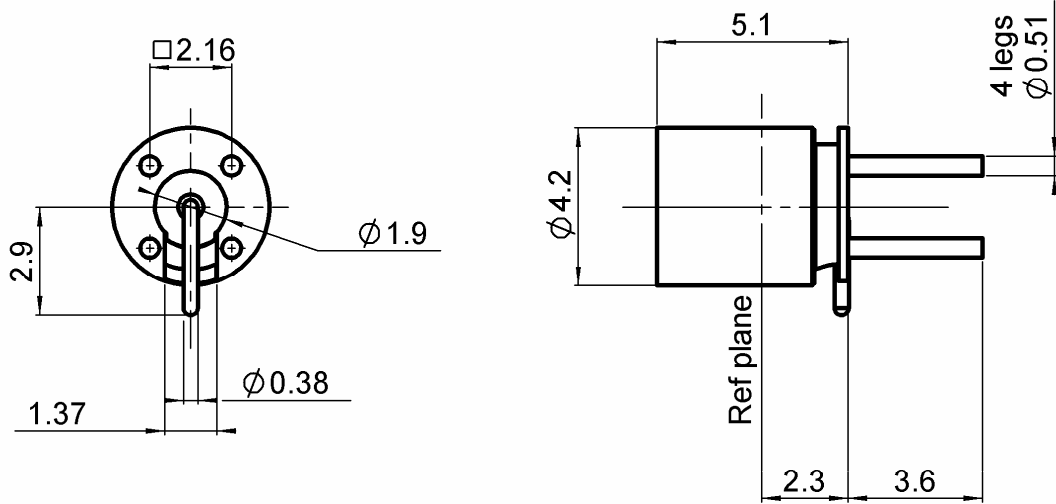

All dimensions are in mm.

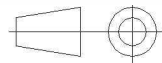

COMPONENTS	MATERIALS	PLATINGS (µm)
BODY	STAINLESS STEEL + BRASS	PASSIVATED + GOLD 0.5 OVER NICKEL 2
CENTER CONTACT	BERYLLIUM COPPER	GOLD 1.27 OVER NICKEL 1.27
OUTER CONTACT	-	
INSULATOR	PTFE	
GASKET	-	
OTHERS PARTS	-	
-	-	
-	-	

Issue : 0914 C

In the effort to improve our products, we reserve the right to make changes judged to be necessary.



MALE STRAIGHT RECEPTACLE FOR PCB

R222.428.700

PIN IN PASTE - SMOOTH BORE

Series : SMP

PACKAGING

SPECIFICATION

Standard	Unit	Other
100	'W' option	Contact us

ELECTRICAL CHARACTERISTICS

ENVIRONMENTAL

Impedance	50	Ω
Frequency	0-18	GHz
VSWR	1.15* + 0,0000	x F(GHz) Maxi
Insertion loss	0.12	\sqrt{F} (GHz) dB Maxi
RF leakage	- (NA)	- F(GHz)) dB Maxi
Voltage rating	335	Veff Maxi
Dielectric withstanding voltage	500	Veff mini
Insulation resistance	5000	M Ω mini

Operating temperature	-65/+165	$^{\circ}$ C
Hermetic seal	NA	Atm.cm3/s
Panel leakage	NA	

OTHERS CHARACTERISTICS

Assembly instruction

Others :
Compliant with MIL-STD-348
*At 12.4GHz - Performance strongly depends on lay out and PCB material

MECHANICAL CHARACTERISTICS

Center contact retention		
Axial force – Mating end	6.8	N mini
Axial force – Opposite end	6.8	N mini
Torque		N.cm mini
Recommended torque		
Mating	NA	N.cm
Panel nut	NA	N.cm
Mating life	1000	Cycles mini
Weight	0,3500	g

Issue : 0914 C

In the effort to improve our products, we reserve the right to make changes judged to be necessary.



PRELIMINARY

MALE STRAIGHT RECEPTACLE FOR PCB

R222.428.700

PIN IN PASTE - SMOOTH BORE

Series : SMP

SOLDER PROCEDURE

1. Deposition of solder paste 'Sn Ag4 Cu0.5' on mounting zone by screen printing application. We recommend a low residue flux.
We advise a thickness of 150 microns (5.85 microinch). Verify that the edges of the zone are clean.
2. Placement of the receptacle on the mounting zone with an automatic machine of 'pick and place' type.
Video camera is recommended for the positioning of the component. Adhesive agents must not be used on the receptacle.
3. Soldering by infra-red reflow.
Below, please find the typical profile to use.
4. Cleaning of printed circuit boards.
5. Checking of solder joints and position of the component by visual inspection.

TEMPERATURE PROFILE

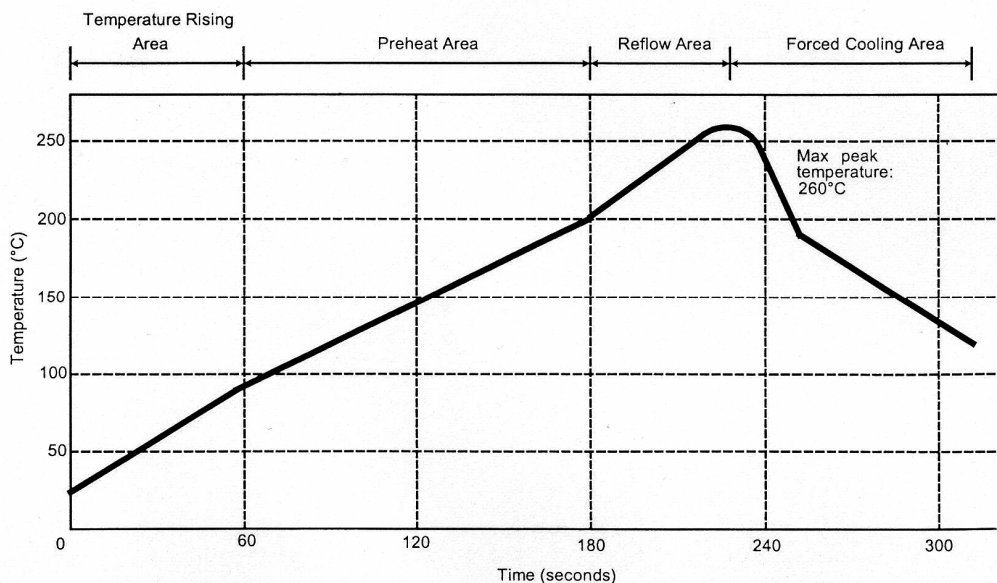

Parameter	Value	Unit
Temperature rising Area	1 - 4	°C/sec
Max Peak Temperature	260	°C
Max dwell time @260°C	10	sec
Min dwell time @235°C	20	sec
Max dwell time @235°C	60	sec
Temperature drop in cooling Area	-1 to - 4	°C/sec
Max dwell time above 100°C	420	sec

Issue : 0914 C

In the effort to improve our products, we reserve the right to make changes judged to be necessary.



PROHIBIT

MALE STRAIGHT RECEPTACLE FOR PCB

R222.428.700

PIN IN PASTE - SMOOTH BORE

Series : SMP

RECOMMENDED PAD DIMENSIONS:

Substrate: RT5880 thickness 0.254mm, with copper layer 35µm on both sides :
 Add vias between both sides along upper ground plane according to engineering practise

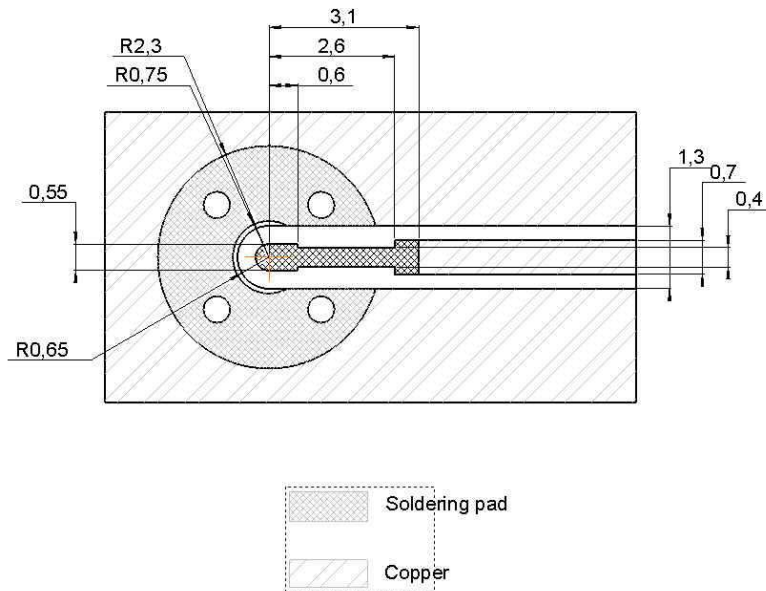

Substrate: RO4350 thickness 0.254mm, with copper layer 35µm on both sides :
 Add vias between both sides along upper ground plane according to engineering practise

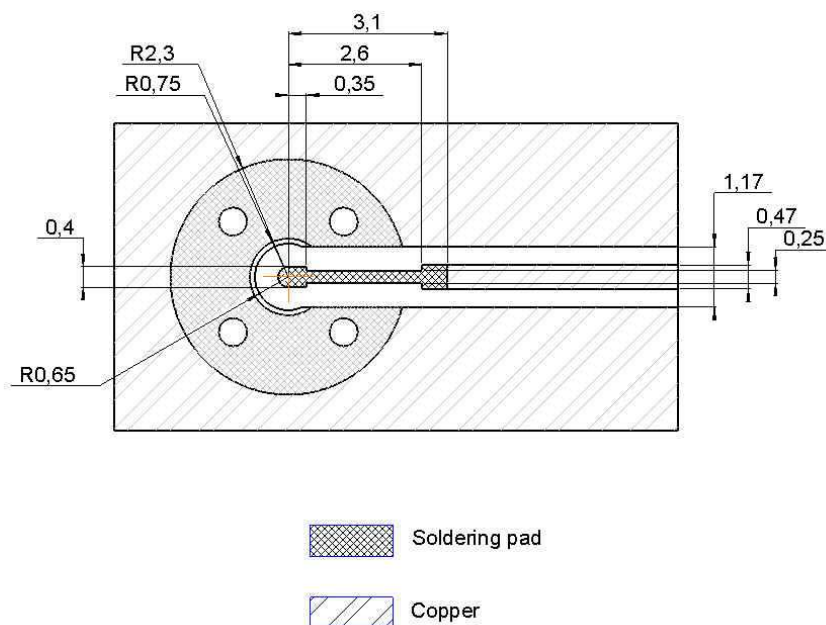

Issue : 0914 C

In the effort to improve our products, we reserve the right to make changes judged to be necessary.



MALE STRAIGHT RECEPTACLE FOR PCB

R222.428.700

PIN IN PASTE - SMOOTH BORE

Series : SMP

Substrate: RO6002 thickness 0.254mm, with copper layer 35µm on both sides :
 Add vias between both sides along upper ground plane according to engineering practise

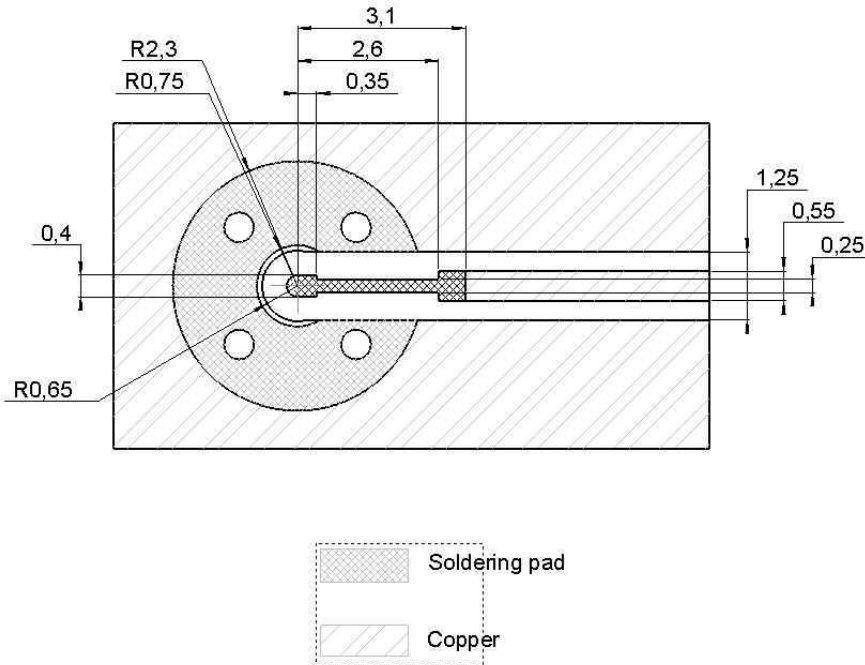

SHADOW FOR VIDEO CAMERA

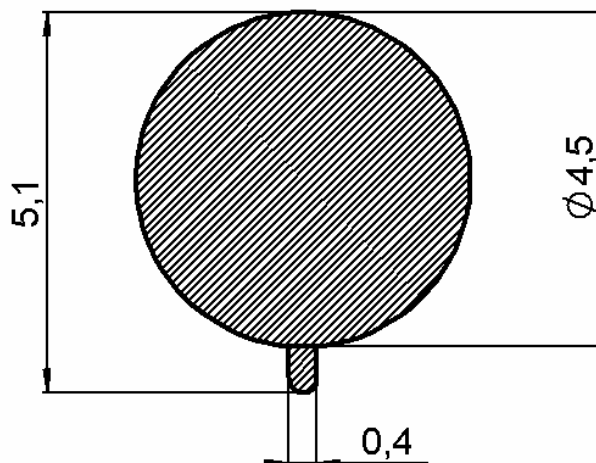

Issue : 0914 C

In the effort to improve our products, we reserve the right to make changes judged to be necessary.

