

LOC		DIST		REVISIONS			
P	LTN	DESCRIPTION	DATE	DWN	APVD		
A		RELEASED	11APR2018	KM	KD		

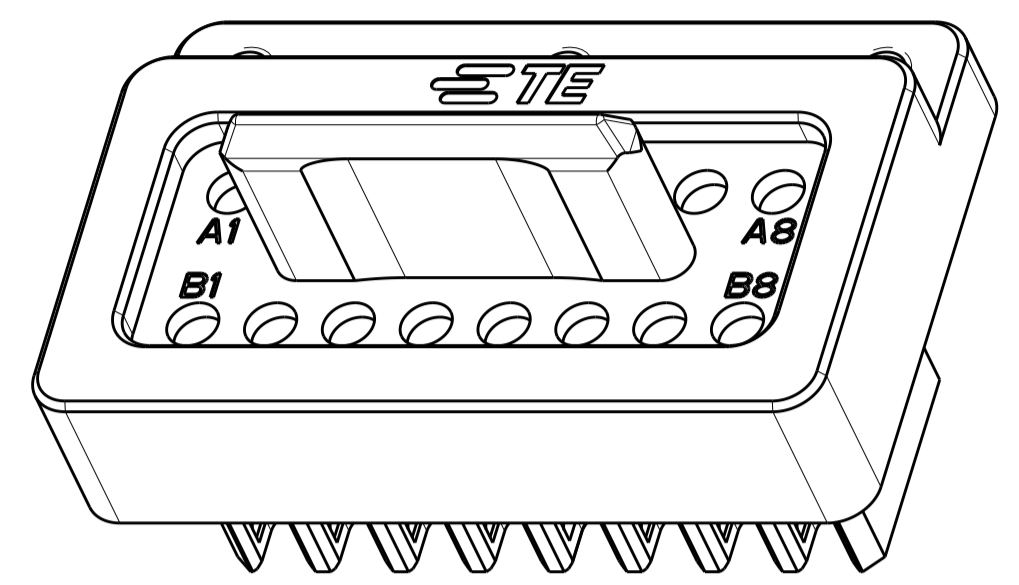

SCALE 4:1

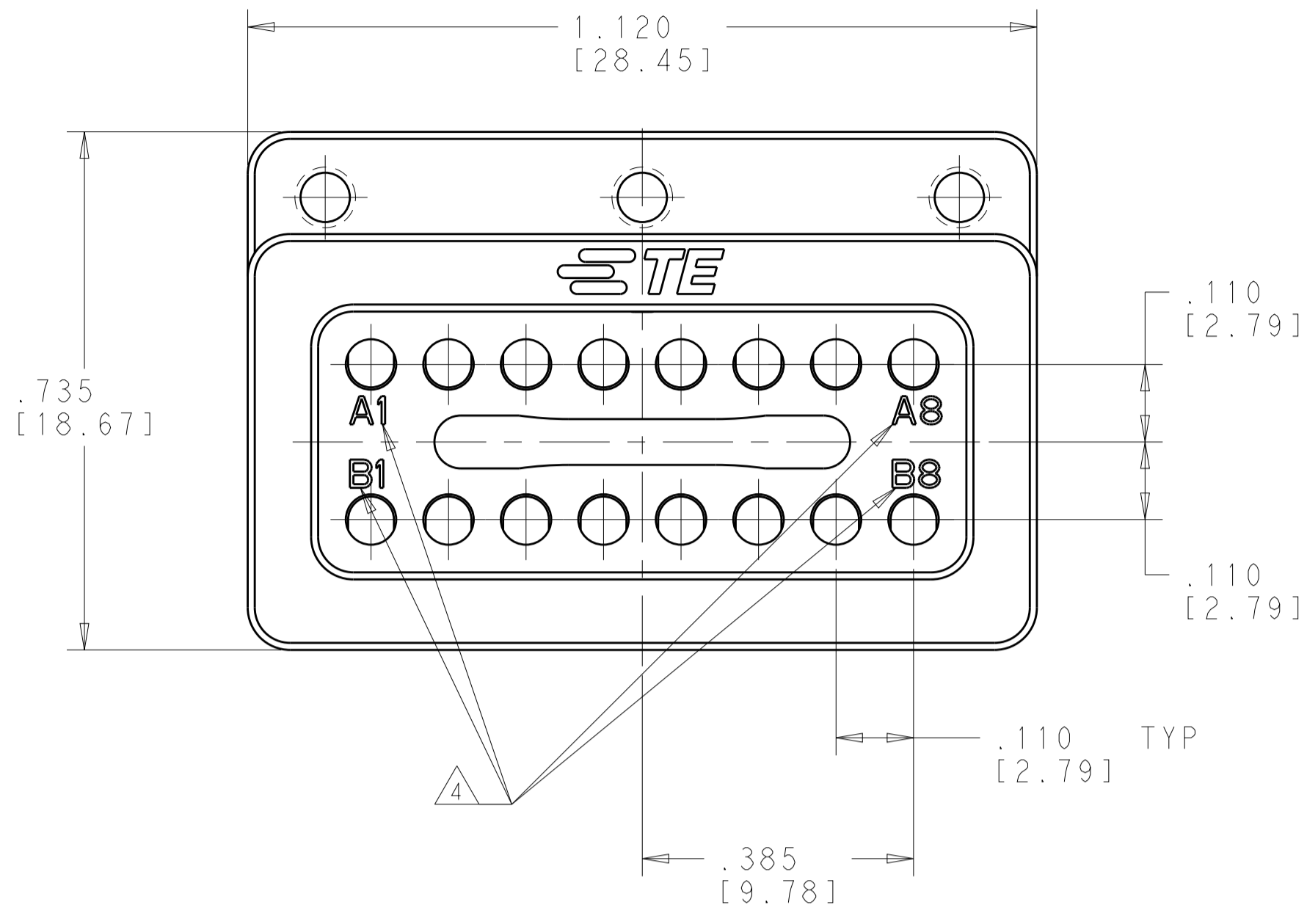
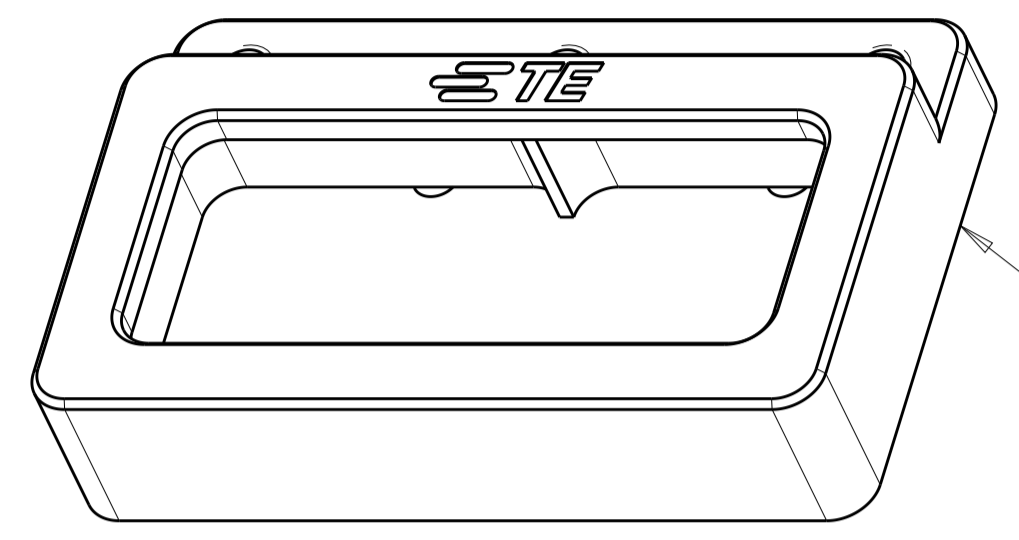

MODULE BODIES

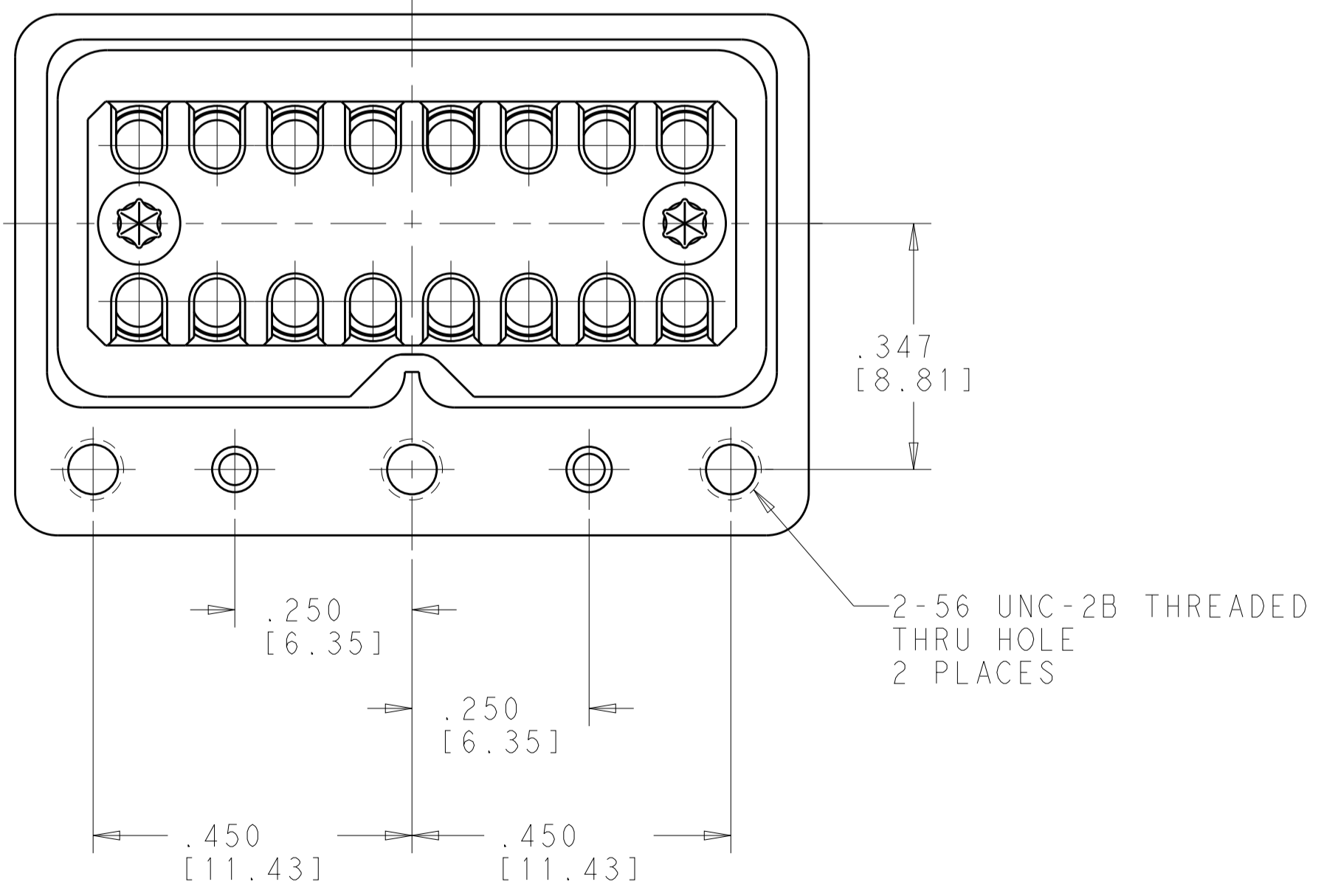
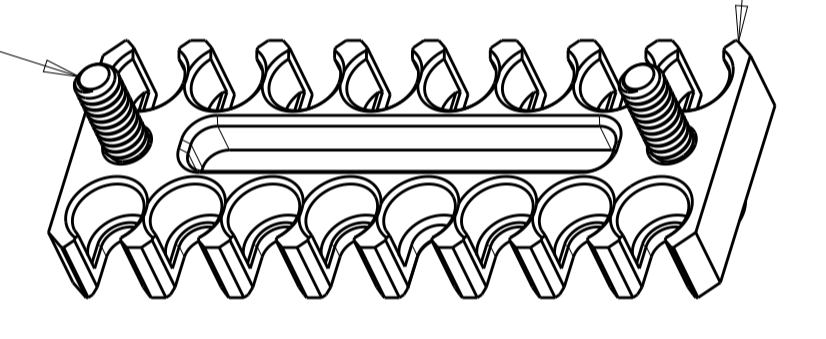
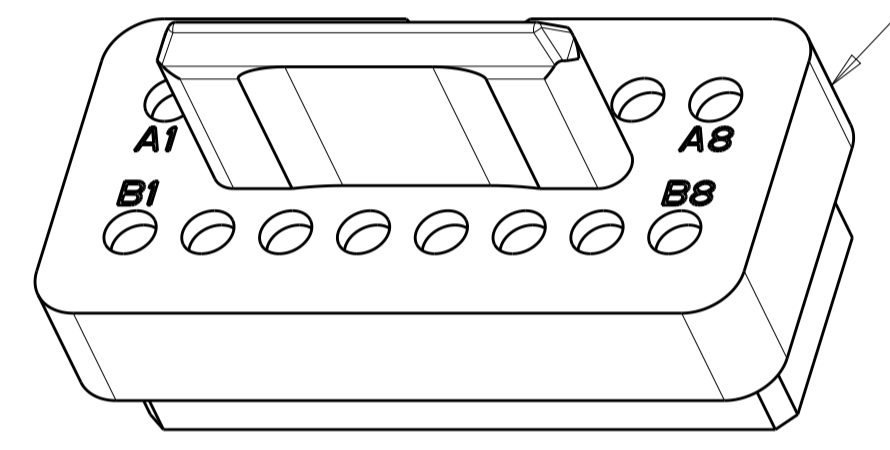
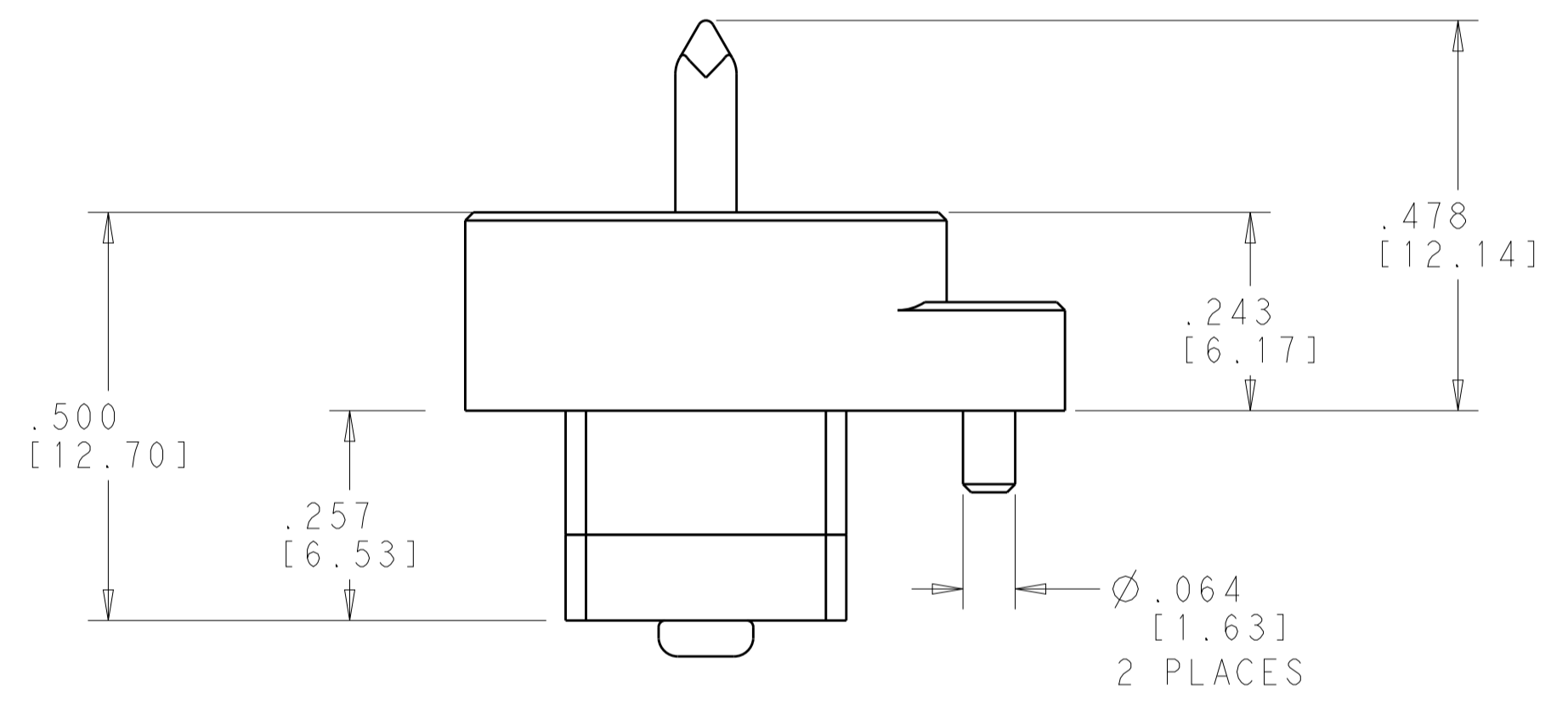
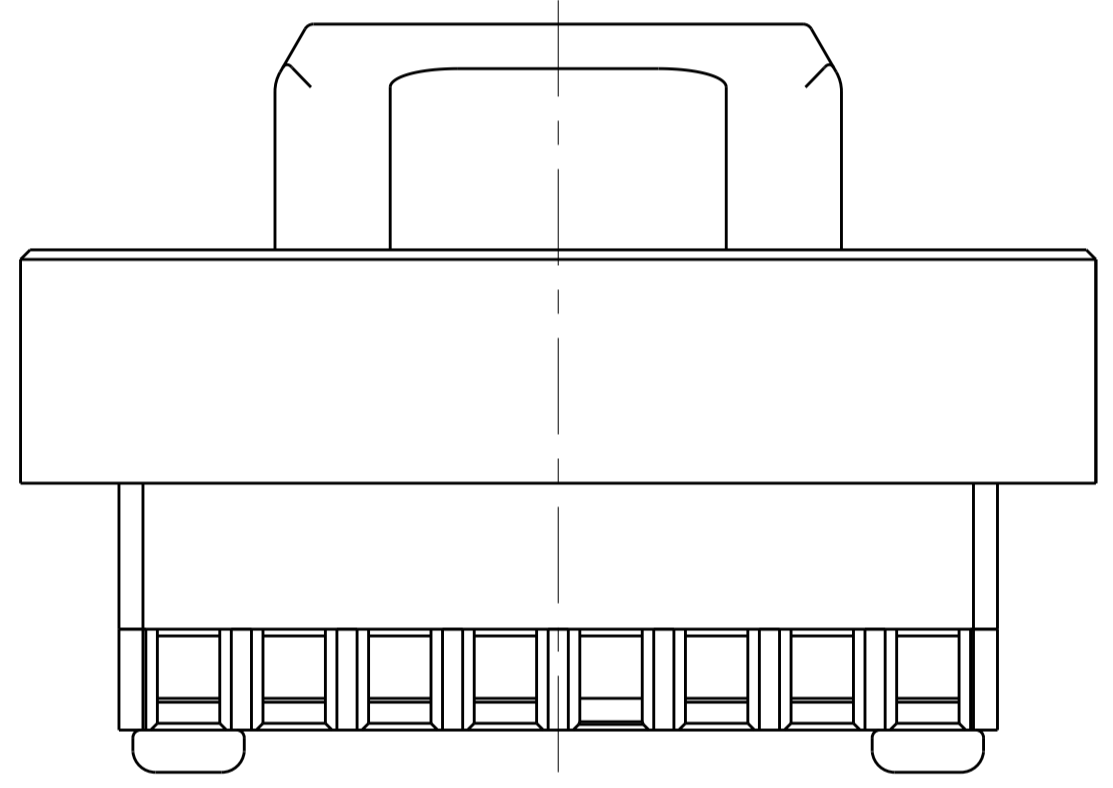

- 1 MATERIAL:
MODULE BODIES - SEE TABLE
GUIDE PIN - STAINLESS STEEL, PER UNS S30300
SCREWS - 300 SERIES STAINLESS STEEL
- 2 FINISH:
MODULE BODIES - SEE TABLE
SCREWS AND GUIDE PIN - PASSIVATED
- 3. SHIPPED IN KIT FORM.
- 4 CIRCUIT IDENTIFICATION MARKING
- 5 J3 MODULE LOCATION CAN BE MOVED -.129[3.28] TO POSITION J3 = 3.892[98.86] TO ALLOW FOR USE OF A FULL MULTIGIG CONNECTOR IN J4. THE DAUGHTERCARD MODULE POSITION MUST ALSO BE ADJUSTED ACCORDINGLY.
- 6 PRELIMINARY PART NUMBER - PART HAS NOT BEEN QUALIFIED

CLEAR CHROMATE CONVERSION COATING	ALUMINUM ALLOY 7075	2828395-2
PASSIVATED	STAINLESS STEEL PER UNS S30300	2828395-1
MODULE FINISH 2	MODULE MATERIAL 1	PART NUMBER

THIS DRAWING IS A CONTROLLED DOCUMENT.		DWN: R. MILLER 06AUG2015	TE Connectivity
DIMENSIONS: INCHES/mm		CHK: C. YI 14AUG25015	
TOLERANCES UNLESS OTHERWISE SPECIFIED:		APVD: K. DOWNHOWER 11APR2018	NAME: 16 POSITION NanoRF MODULE P.C.B. MOUNT - BACKPLANE VITA
0 PLC ±		PRODUCT SPEC: 108-163006	
1 PLC ±		APPLICATION SPEC: 408-163016	RESTRICTED TO
2 PLC ±		WEIGHT: -	SCALE: 5:1
3 PLC ±.005[0.13]		CUSTOMER DRAWING	SHEET 1 OF 2
4 PLC ±		REVISIONS	REV A
ANGLES ±			
FINISH NOTE 2			

LOC		DIST		REVISIONS			
P	LTN	DESCRIPTION	DATE	DMN	APVD		
-	-	SEE SHEET 1	-	-	-		

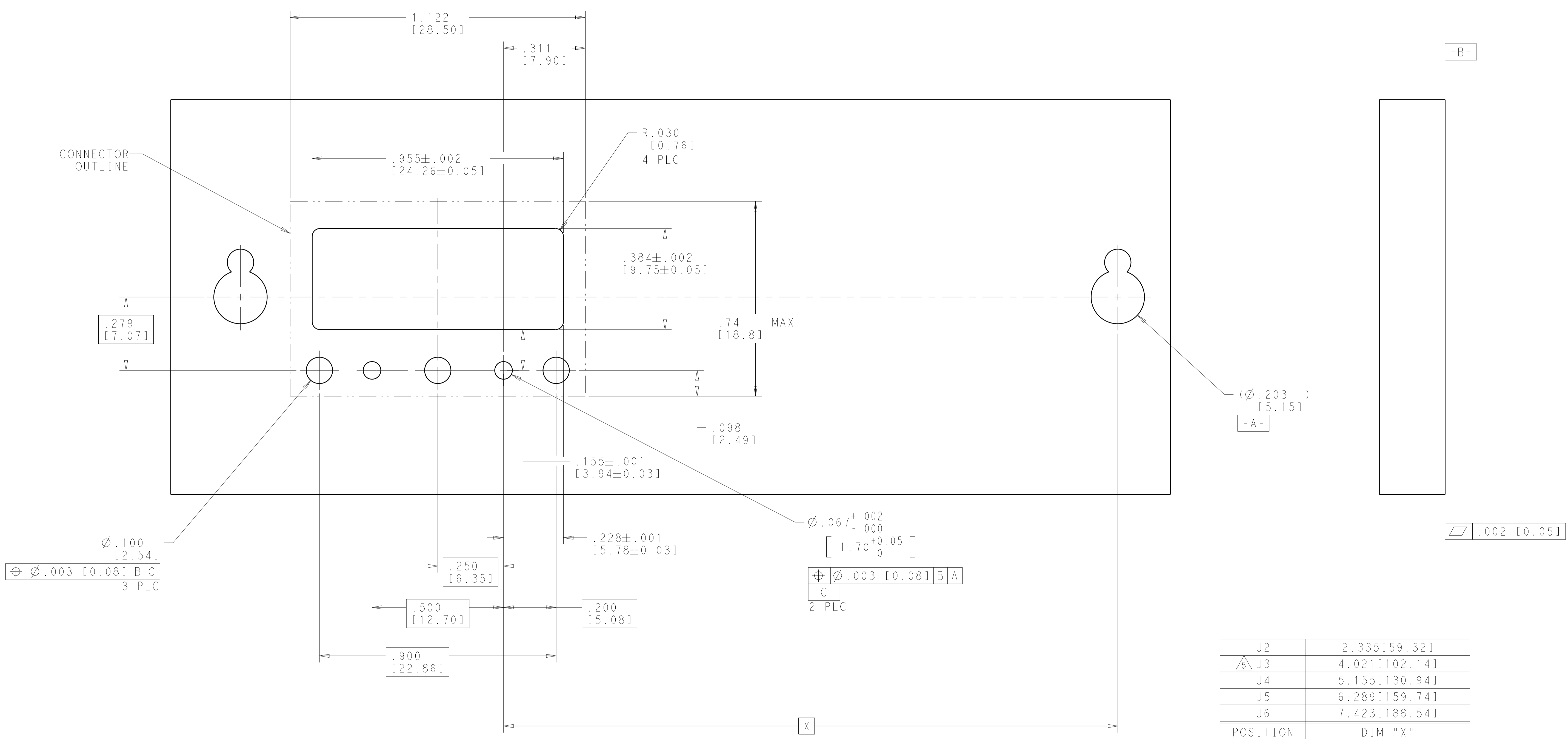

J2	2.335 [59.32]
J3	4.021 [102.14]
J4	5.155 [130.94]
J5	6.289 [159.74]
J6	7.423 [188.54]
POSITION	DIM "X"

TYP PCB LAYOUT - VIEWED FROM BACKSIDE OF BACKPLANE

THIS DRAWING IS A CONTROLLED DOCUMENT.		DMN R. MILLER 06AUG2015	TE Connectivity
DIMENSIONS: INCHES/mm		CHK C. YI 14AUG25015	
TOLERANCES UNLESS OTHERWISE SPECIFIED:		APVD K. DOWNHOWER 11APR2018	NAME 16 POSITION NanoRF MODULE P.C.B. MOUNT - BACKPLANE VITA
		PRODUCT SPEC 108-163006	RESTRICTED TO
MATERIAL NOTE 1		APPLICATION SPEC 408-163016	SIZE A100779
NOTE 2		WEIGHT	CAGE CODE 2828395
		CUSTOMER DRAWING	SCALE 5:1 SHEET 2 OF 2 REV A