

NOTES:

13-020-1085-00

Materials: SST. corrosion-resistant, Non Magnetic 303, per ASTM A484 and A582. Beryllium Copper per ASTM-B-196, QQ-C-530
PTFE Fluorocarbon per ASTM-D-1710 Type 1

Finish: Center Conductors and solder components shall be plated per MIL-G-45204 Type II, Class 1 over Nickel plate per QQ-N-290.
Body and Body components shall be passivated per ASTM A380.

Frequency: DC-34.5 GHz

VSWR: 1.25 TO 34.5 GHz

Insertion Loss: $.05\sqrt{\text{Frequency}}$

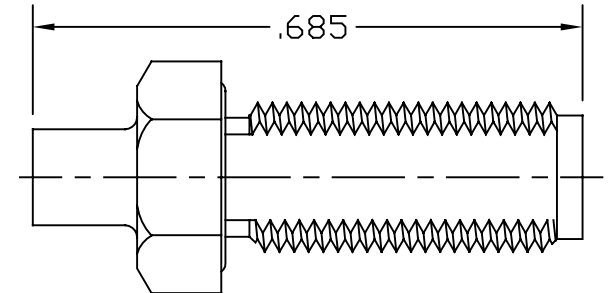

LTR	DESCRIPTION	DATE	APPR.	DRAWN <i>LMW</i>	CHECKED	USED ON	 SRI CONNECTOR GAGE CO. 751 NORTH DRIVE MELBOURNE FL. 32934													
—	REL	09/03		APPR.	SCALE	13-020-1085-00														
				UNLESS OTHERWISE SPECIFIED: 1. REMOVE ALL BURRS 2. BREAK ALL CORNERS & EDGES .005 R. MAX 3. CHAMFER 1st & LAST THREADS 45° 4. SURFACE FINISHED 32/ UNLESS OTHERWISE SPECIFIED. 5. DIAMETERS ON COMMON CENTERS TO BE CONCENTRIC WITHIN .002 T.I.R. 6. ALL DIMENSIONS ARE AFTER PLATING.		MATERIAL	TITLE													
				DIMENSIONS ARE IN INCHES TOLERANCES		FINISH	SSMA JACK BLKHD TO .085 S/R													
				<table border="1"> <tr> <th>DECIMALS</th> <th>FRACTIONAL</th> <th>ANGULAR</th> </tr> <tr> <td>.X ±.030</td> <td></td> <td>.X° ±1'0"</td> </tr> <tr> <td>.XX ±.010</td> <td>± 1/64</td> <td>.X°X' ±15'</td> </tr> <tr> <td>.XXX ±.005</td> <td></td> <td></td> </tr> </table>	DECIMALS	FRACTIONAL		ANGULAR	.X ±.030		.X° ±1'0"	.XX ±.010	± 1/64	.X°X' ±15'	.XXX ±.005			SIZE	FSCM NO.	SHEET
DECIMALS	FRACTIONAL	ANGULAR																		
.X ±.030		.X° ±1'0"																		
.XX ±.010	± 1/64	.X°X' ±15'																		
.XXX ±.005																				
						A	OHMO1	1	13-020-1085-00											