

REVISIONS			
REV	DESCRIPTION	DATE	APPROVED
A	ECN #7774	11/18/09	A.D.M.

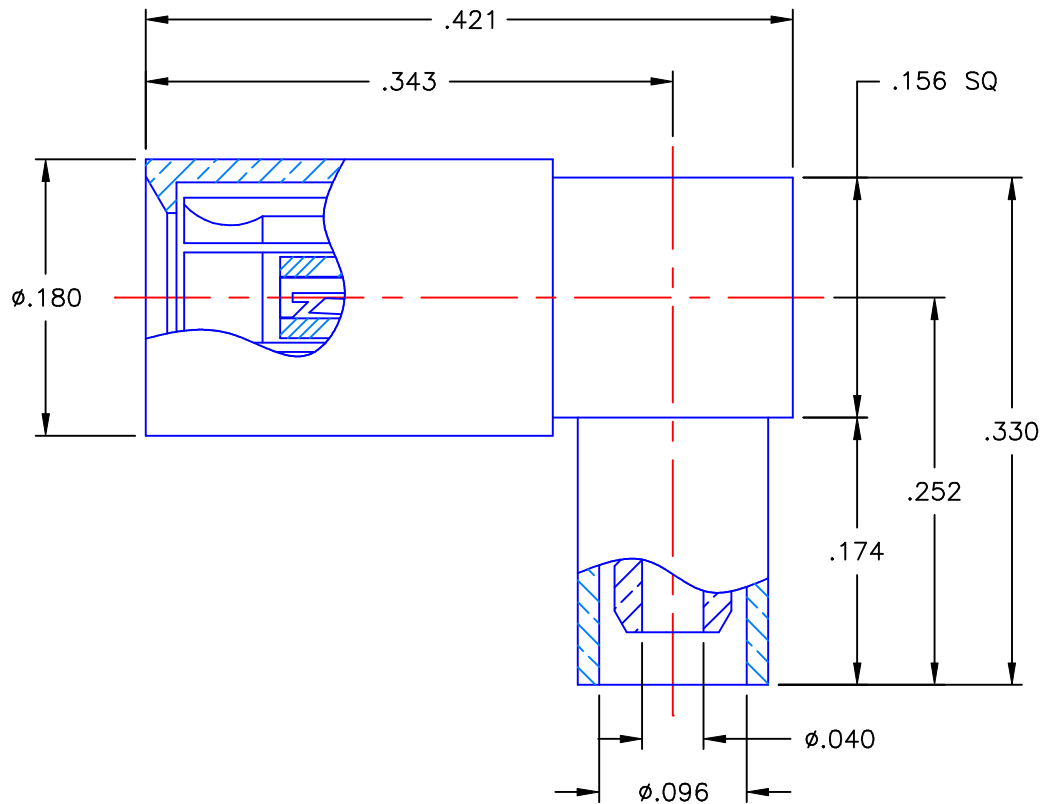

NOTES:

MATERIALS:

1. INTERFACE BODY & CONTACT = BERYLLIUM COPPER PER ASTM B196, ALLOY C17300, TEMPER TD04.
2. INSULATORS = VIRGIN WHITE TEFLON PER ASTM D1710, GRADE 1, TYPE I, CLASS "B".
3. CRIMP SLEEVE = SEAMLESS LOWLEAD BRASS TUBE, ALLOY 330, SOFT ANNEAL TEMPER, .025/.060 GRAIN SIZE OR SEAMLESS COPPER TUBE PER ASTM B75, TYPE C12000, TEMPER: LIGHT ANNEAL O50 EXCEPT YIELD STRENGTH.
4. SHRINK TUBE = RNF100 (NOT SHOWN)
5. ALL OTHER METAL PARTS = BRASS PER ASTM B16, ALLOY C36000, TEMPER H02.

FINISHES:

1. BODIES = GOLD PLATE PER MIL-G-45204, TYPE II, CLASS 0, GRADE C, OVER .00010 TO .00020 COPPER STRIKE PER MIL-C-14550.
2. CONTACT = GOLD PLATE PER MIL-G-45204, TYPE II, CLASS 1, GRADE C, OVER .0001 TO .0002 COPPER STRIKE PER MIL-C-14550.
3. ALL OTHER METAL PARTS = NICKEL PLATE PER QQ-N-290, CLASS 1, GRADE G, EXCEPT .0001 TO .0002 THICK OVER .00005 TO .0001 THICK COPPER PER MIL-C-14550.

Property of Radiall Incorporated
 This document cannot be reproduced or communicated to a third party without prior written permission of RADIALL Incorporated.

UNLESS OTHERWISE SPECIFIED DIMENSIONS ARE IN INCHES TOLERANCES ON	DWN:	DATE	
	A.D.M.	11/18/09	
	CHKD:	DATE	
DECIMAL	ANGLE	D.N.	11/18/09
		APVD:	DATE
		J.M.	11/18/09

AEP APPLIED ENGINEERING PRODUCTS
 a RADIALL company
 104 John W. Murphy Dr.
 New Haven, CT 06513

SSMB RIGHT ANGLE FEMALE PLUG
 CRIMP TYPE
 FOR RG-178 & SIMILAR CABLES

REFERENCE:	MATERIALS & FINISHES:
ORIGINATOR: A.D.M. DATE: 02/08/07	SEE NOTES

SIZE A	FSCM NO. 19505	DWG NO. 7405-2521-002	REV A
SCALE 8:1	THIRD ANGLE PROJECTION		SHEET 1 OF 1

7405-2521-002