

NOTES:

22-000-1559-00

**Materials:** SST. corrosion-resistant, Non Magnetic 303, per ASTM A484 and A582. Beryllium Copper per ASTM-B-196, QQ-C-530 REXOLITE 1422

**Finish:** Center Conductors and solder components shall be plated per MIL-G-45204 Type II, Class 1 over Nickel plate per QQ-N-290. Body and Body components shall be passivated per ASTM A380.

**Frequency:** DC-34.5 GHz

**VSWR:** 1.25 TO 34.5 GHz

**Insertion Loss:**  $.05\sqrt{\text{Frequency}}$

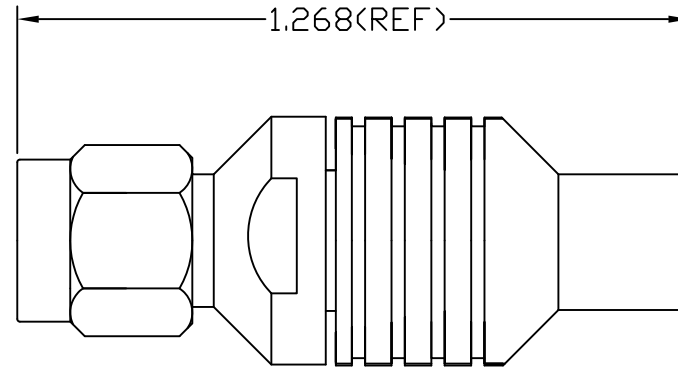

LTR	DESCRIPTION	DATE	APPR.	DRAWN <b>SM</b>	CHECKED	USED ON	 SRI CONNECTOR GAGE CO. 751 NORTH DRIVE MELBOURNE FL. 32934		
-	REL	10/06		APPR.	SCALE	22-000-1559-00			
				UNLESS OTHERWISE SPECIFIED: 1. REMOVE ALL BURRS 2. BREAK ALL CORNERS & EDGES .005 R. MAX 3. CHAMFER 1st & LAST THREADS 45° 4. SURFACE FINISHED 32✓ UNLESS OTHERWISE SPECIFIED. 5. DIAMETERS ON COMMON CENTERS TO BE CONCENTRIC WITHIN .002 T.I.R. 6. ALL DIMENSIONS ARE AFTER PLATING.		MATERIAL	TITLE  3.5mm PLUG TO SF-142B		
				DIMENSIONS ARE IN INCHES TOLERANCES DECIMALS      FRACTIONAL      ANGULAR .X            ±.030 .XX          ±.010 .XXX        +.005 ± 1/64 .X°        ±1°0' .X°X'     ±15'		FINISH			
						SIZE	FSCM NO.	SHEET	DWG. NO.
						A	OHMO1	1	22-000-1559-00