

NOTES:

52-000-1597-00

Materials: SST. corrosion-resistant, Non Magnetic 303, per ASTM A484 and A582. Beryllium Copper per ASTM-B-196, QQ-C-530 PTFE Fluorocarbon per ASTM-D-1710

Finish: Center Conductors and solder components shall be plated per MIL-G-45204 Type II, Class 1 over Nickel plate per QQ-N-290. Body and Body components shall be passivated per ASTM A380.

Frequency: DC-18 GHz

VSWR: 1.2:1 to 18GHz

Insertion Loss: $.05\sqrt{\text{Frequency}}$

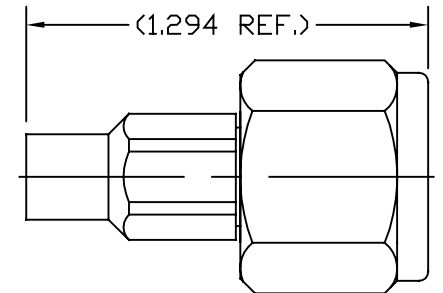

LTR	DESCRIPTION	DATE	APPR.	DRAWN LMW	CHECKED	USED ON	 SRI CONNECTOR GAGE CO. 751 NORTH DRIVE MELBOURNE FL. 32934															
-	REL	11/02		APPR.	SCALE	52-000-1597-00	TITLE															
				UNLESS OTHERWISE SPECIFIED: 1. REMOVE ALL BURRS 2. BREAK ALL CORNERS & EDGES .005 R. MAX 3. CHAMFER 1st & LAST THREADS 45° 4. SURFACE FINISHED 32/ UNLESS OTHERWISE SPECIFIED. 5. DIAMETERS ON COMMON CENTERS TO BE CONCENTRIC WITHIN .002 T.I.R. 6. ALL DIMENSIONS ARE AFTER PLATING.			TYPE N PLUG TO LL142															
				DIMENSIONS ARE IN INCHES TOLERANCES			MATERIAL	FINISH														
				<table border="1"> <thead> <tr> <th>DECIMALS</th> <th>FRACTIONAL</th> <th>ANGULAR</th> </tr> </thead> <tbody> <tr> <td>.X ±.030</td> <td></td> <td>.X° ±1°0'</td> </tr> <tr> <td>.XX ±.010</td> <td>± 1/64</td> <td>.X°X' ±15'</td> </tr> <tr> <td>.XXX ±.005</td> <td></td> <td></td> </tr> </tbody> </table>			DECIMALS		FRACTIONAL	ANGULAR	.X ±.030		.X° ±1°0'	.XX ±.010	± 1/64	.X°X' ±15'	.XXX ±.005			SIZE	FSCM NO.	SHEET
DECIMALS	FRACTIONAL	ANGULAR																				
.X ±.030		.X° ±1°0'																				
.XX ±.010	± 1/64	.X°X' ±15'																				
.XXX ±.005																						
						A	OHMO1	1	52-000-1597-00													