

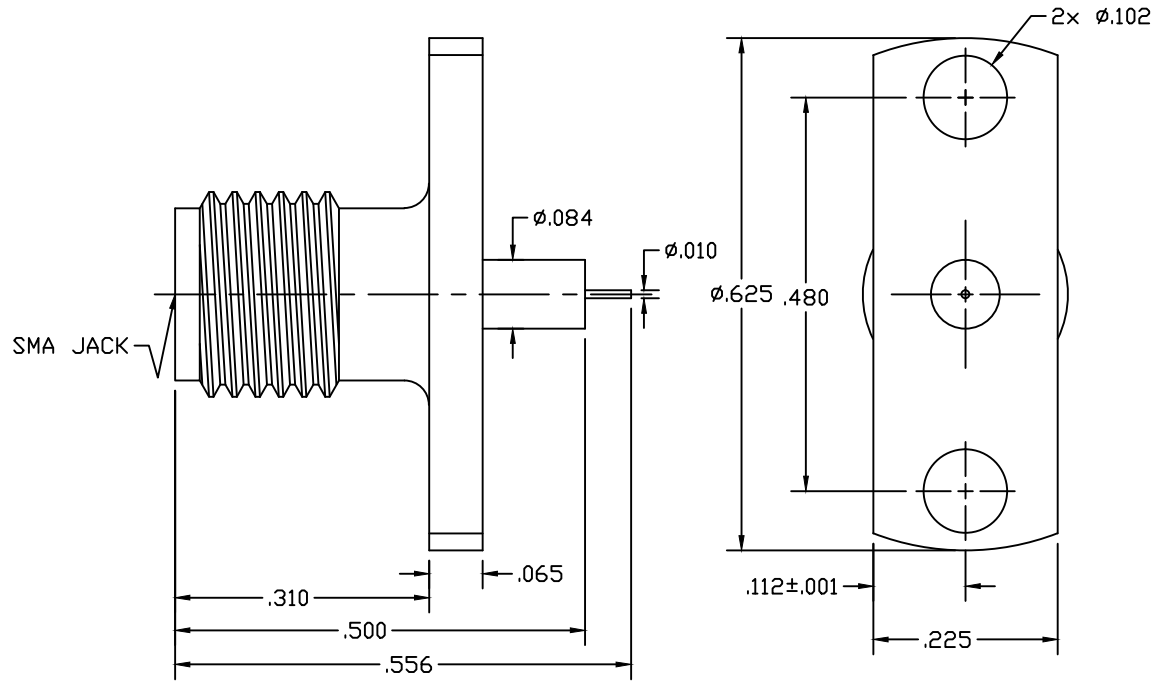

NOTES:

21-130-1000-04

- Materials:** SST. corrosion-resistant, Non Magnetic 303, per ASTM A484 and A582. Beryllium Copper per ASTM-B-196, QQ-C-530
PTFE Fluorocarbon per ASTM-D-1710
- Finish:** Center Conductors and solder components shall be plated per MIL-G-45204 Type II, Class 1 over Nickel plate per QQ-N-290.
Body and Body components shall be gold plated per MIL-G-45204
- Frequency:** DC-27 GHz
- VSWR:** 1.2 TO 27 GHz
- Insertion Loss:** $.05\sqrt{\text{Frequency}}$



LTR	DESCRIPTION	DATE	APPR.	DRAWN LMW	CHECKED	USED ON	 SRI CONNECTOR GAGE CO. 751 NORTH DRIVE MELBOURNE FL. 32934		
-	REL	03/03		APPR.	SCALE	21-130-1000-04			
				UNLESS OTHERWISE SPECIFIED: 1. REMOVE ALL BURRS 2. BREAK ALL CORNERS & EDGES .005 R. MAX 3. CHAMFER 1st & LAST THREADS 45° 4. SURFACE FINISHED 32√ UNLESS OTHERWISE SPECIFIED. 5. DIAMETERS ON COMMON CENTERS TO BE CONCENTRIC WITHIN .002 T.I.R. 6. ALL DIMENSIONS ARE AFTER PLATING.		MATERIAL	TITLE		
				DIMENSIONS ARE IN INCHES TOLERANCES		FINISH	SMA JACK (2) HOLE FLANGE		
				DECIMALS .X ±.030 .XX ±.010 .XXX +.005	FRACTIONAL ± 1/64	ANGULAR .X° ±1°0' .X'X' ±15'		SIZE	
								FSCM NO. OHMO1	SHEET 1