

| PART NO. | CABLE | (A) DIM | (B) DIM |
|----------|--------|---------|---------|
| 531-1 | RG-405 | .089 | .12 |
| 531-2 | RG-402 | .145 | .18 |

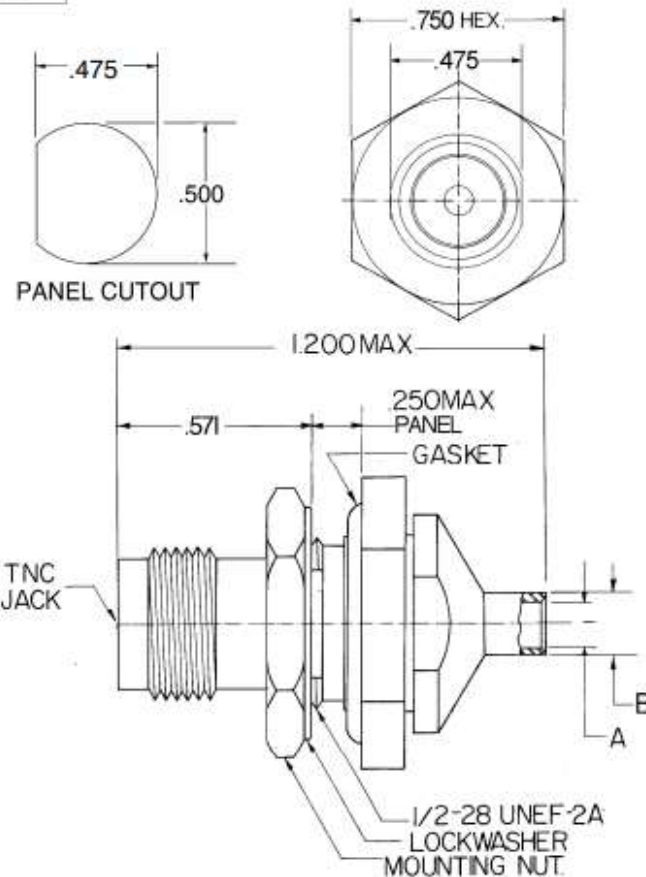

5. VSWR NOT TO EXCEED 1.20:1 FROM DC TO 11.0 GHZ & 1.30:1 FROM 11GHZ TO 18 GHZ
4. CONNECTOR TO MEET OR EXCEED ALL SPECIFICATIONS PER MIL-39012
3. FINISH:
 BODY AND MOUNTING NUT: NICKLE PER QQ-N-290
 SOLDER BODY SUB ASSEMBLY: GOLD PER MIL-G-45204
 CONTACT: GOLD PER MIL-G-45204: TYPE II, CLASS 2, OVER COPPER PER MIL-C-14550, CLASS 4
2. MATERIAL:
 BODY: BRASS PER QQ-B-626
 SOLDER BODY SUB ASSEMBLY: BRASS QQ-B-626
 MOUNTING NUT: BRASS PER QQ-B-626
 CONTACT: BERYL. COPPER PER QQ-C-530
 INSULATOR: TEFLON PER MIL-P-19468A
1. MATING DIMS IN ACCORDANCE WITH MIL-STD-348

NOTES :

NOTICE

This drawing embodies a CONFIDENTIAL proprietary design originated by United Microwave Products, Inc., and all design, manufacturing, reproduction, use and sale rights regarding the same are expressly reserved. It is submitted under a confidential relationship for a specified purpose and the recipient agrees by accepting this drawing not to supply or disclose any information regarding it to any unauthorized person or to incorporate in other projects any special feature peculiar to this design. All patent rights hereto are expressly reserved by United Microwave Products Inc.

- TOLERANCES AND NOTES** EXCEPT AS NOTED
DIMENSIONS ARE IN INCHES
 LINEAR .XX ± .015 ANGULAR ± 1/2° FRACTION ± 1/32
 XXX ± .005
1. MACHINE FINISH \sqrt{RMS}
 2. BREAK ALL SHARP EDGES .002
 3. ALL MACHINED FILLETS
 4. ALL MACHINED SURFACES SQUARE TO RESPECTIVE AXIS WITHIN .003 PER INCH.
 5. MACHINED DIAMETERS TO BE CONCENTRIC WITHIN .002 - .003 T.I.R.
 6. DIMENSIONS TO BE MET BEFORE PLATING.
 7. CHAMFER ALL THDS. 45 DEGREES
 8. THREADS PER H-2B
 9. REMOVE FRAYED EDGES ON TEFLON.
 10. REMOVE ALL BURRS.

UNITED MICROWAVE PRODUCTS Inc.

TNC JACK BULKHEAD FEED THROUGH CABLE DIRECT SOLDER

| MATERIAL | SIZE | SPECIFICATION | PROCUREMENT |
|----------|------|---------------|-------------|
| | | APPR. | |
| | | ENG. | |
| | | CHK. | |
| | | DR. | |

531

WEIGHT

SCALE

N/A

NONE