

1.0 PERFORMANCE: (sea level)
 1.1 FREQUENCY RANGE: 2 GHz
 1.2 VOLTAGE RATING: 750 Vrms
 1.3 NOMINAL IMPEDANCE: 75 OHMS
 1.4 DWV: 1500 Vrms, 60 Hz
 1.5 TEMPERATURE RANGE: -65 / +165°C

2.0 MATERIALS (RoHS)
 2.1 LOCK WASHER:
 PHOSPHOR BRONZE
 2.2 DIELECTRIC: PTFE
 2.3 CONTACT: BeCu
 2.4 OTHER METAL: BRASS
 3.0 FINISH: SEE TABLE

4.0 MECHANICAL
 4.1 INTERFACE PER MIL-STD-348
 4.2 CONTACT RETENTION: 6 LBS MIN AXIAL

DWG NO. OL-0505-13-1		REV. C
PART NUMBER 0505-13	BODY NICKEL	CONTACT SILVER
PLATE PER STI 7.3.1-8		

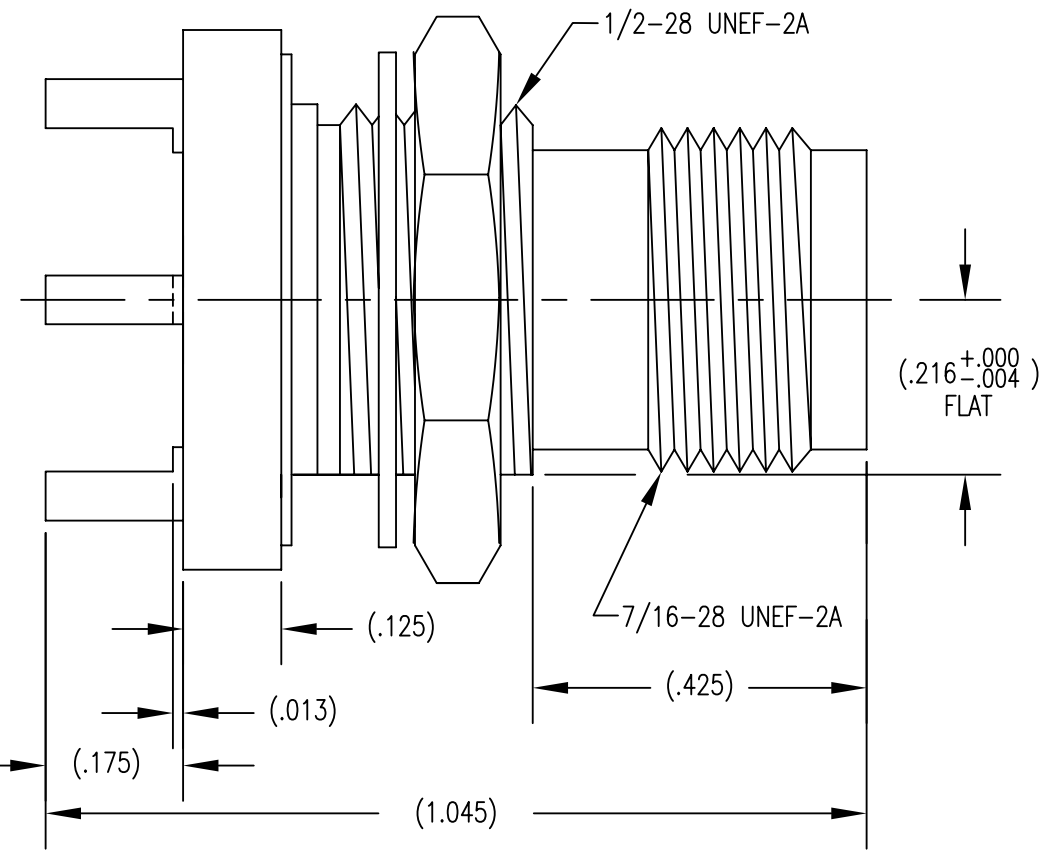
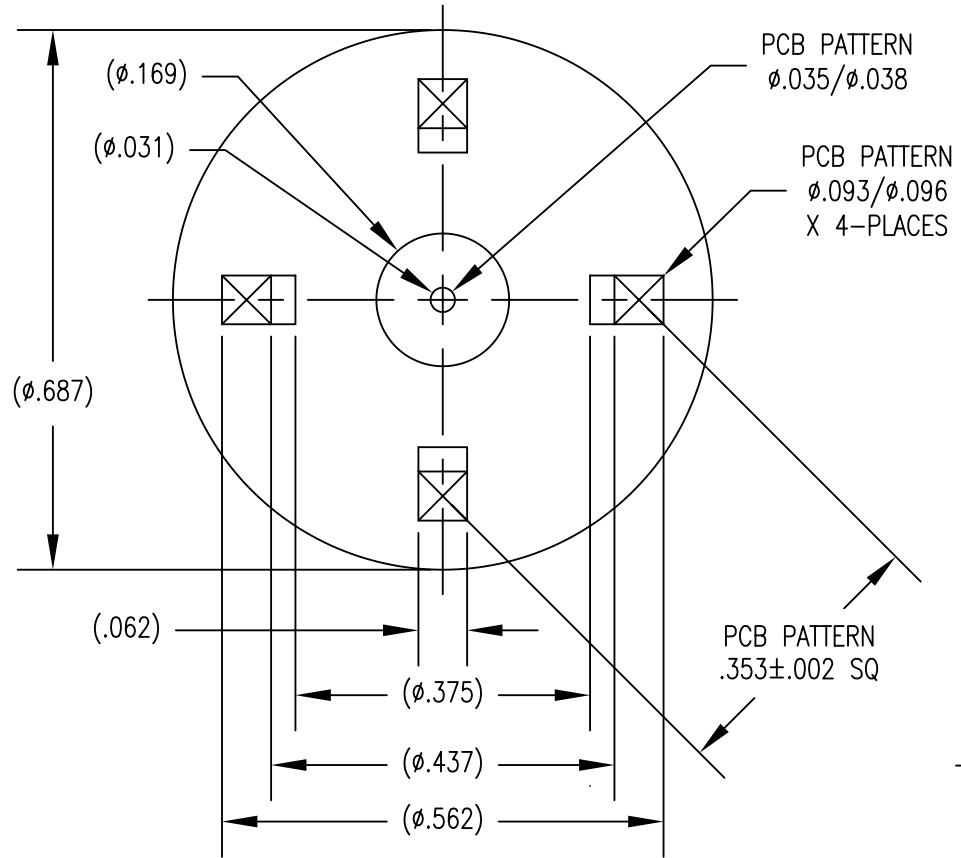

C	ADD NOTES	1/31/08	fsh	fsh
B	WAS: 70 OHMS...	5/28/98	MM	
A	ORIGINAL	1/8/98		
Rev.	Revisions	Date	Dwn.	Appd.
	RECOM. STOCK SIZE	FT/M PCS	QTY REQD	

PROPRIETARY
 THIS DRAWING CONTAINS CONFIDENTIAL INFORMATION PROPRIETARY TO SAN*TRON INC. IT MUST NOT BE REPRODUCED OR DISCLOSED TO OTHERS OR USED IN ANY OTHER WAY, IN WHOLE OR PART EXCEPT AS AUTHORIZED IN WRITING BY SAN*TRON INCORPORATED.

REMOVE ALL BURRS AND SHARP EDGES .005 MAX.
 UNLESS OTHERWISE STATED ALL DIMENSIONS ARE IN INCHES AND APPLY AFTER PLATING

UNSPECIFIED TOL.	DWN	MM	1/8/98
DEC. $\pm .005$	CHKD	SJS	1/26/98
FRAC. $\pm 1/64$	APPR	JTO	1/26/98
ANG. $\pm 1/2^\circ$			

CONCENTRICITY .004 TIR
 ALL MACHINED SUFACES $\sqrt{63}$

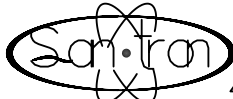
 SAN • TRON, INC.
 4 NEWBURYPORT TPK, IPSWICH, MA 01938

TITLE 75 OHM TNC P.C. BOARD
 (B) RECEPTACLE

MATERIAL: FINISH:

FSCM NO. 50896	DWG NO. OL-0505-13-1	REV. C
SCALE 4:1		